



Bowhill Engineering
Capability Statement

Together we Thrive

CONTENTS

What we do

Core Values

Core Competencies

Capabilities

Low Risk

Safety

ESG

Compliance

Success

Contacts

Project History & Referees

Company Details

Trade References

Facilities & Equipment

B5 High Bay Heavy Lift Workshop

Capability Statement

Services

ECI

Key Differentiators

Key Projects Success Factors

- OZ Mineral Headframe Casey Study
- SX-12 Total Station
- Solutions:
- Early Optimisation (R2P)
- Implemented Learnings (Flinders Link)
- Off Site pre-assembly (Williams St)
- Saved \$350 & 4 weeks on critical path (Darlington)
- Collaborative Model Review (Oaklands)
- Unique, Safe & Efficient (O'Bahn)
- Award winning delivery solution (Majors)
- New launch method saves client 2 months (Ferries)
- Tripling a mines capacity (Mindarie)
- Precision pays off (Wayville)
- Multi-disciplined Engineering Solutions (Mannum)
- Tight tolerances (Maritime)
- Adaptability & Compliance (Air 7000)





We transform communities and our people by optimising and building structures that matter together.

We're specialist fabricators of heavy and complex structural steel. We collaboratively build structures, from design optimisation through to installation, that benefit many Australians.





We do what we
say we are
going to do



We get things
done, together



We Work
Smarter



We help
our clients
win

CORE VALUES

Bowhill Engineering has enjoyed significant growth over the last 5 years and is highly regarded by its customers and stakeholders as a South Australian success story. The company is seen as having a unique position in the market, specialising in large and complex steel structures.

Bowhill Engineering's recent growth has been driven through nurturing collaborative relationships with major construction partners and delivering solid performance on large-scale infrastructure projects (primarily road projects with bridge components).

Customers value the relationship that they have with the Bowhill team, the honesty and transparency, the expertise and (proactive) initiative provided, ensuring cost effective and constructable solutions.

JWPM Consulting – Summary of their External Scan

CORE COMPETENCIES

In an increasingly competitive and high-stakes infrastructure game, you need a bidding edge. And the bidding edge comes from working with a specialist heavy and complex steel fabrication supplier who will partner with you — not just take your order.



Smarter together

Design optimisation specialists in large, welded components

We start by bringing together the team of experts across design, surveying, drafting, engineering, fabrication, surface treatment, transportation/logistics, and erection to ask the questions others don't and find the efficiencies others can't.



Win before you start

Cost with certainty

When you're looking for specialist heavy and complex steel engineering, most fabricators talk quality; we've got 40 years demonstrating it. Our facilities and equipment are set up to handle the heavy, large and complex parts of any project — think train stations and 50m long road bridge girders.



Complexity done excellently

Systems and process, refinement

We're able to offer certainty of costs because we control our end-to-end process by designing, fabricating, preparing, and painting all our steel under one roof. By being able to take care of the transport through to on-site erection, we're able to control what happens to the whole process.



Committed to our community

Strengthen our region

Helping the community isn't something many structural steel engineers boast about, but as a multigeneration family-owned business, contributing to our community is part of our DNA — and it's what sets us apart.

CAPABILITIES

3,000 m² + 8.1m

workshop floor area & one of SA's widest blast rooms



Heavy and oversize transport specialists with 140t on site movement capability

2500t

Structural Steel Capability per year



AS5131 NSSCS CC3 Certified
IIW MCS ISO 3834.2
TfNSW (RMS) pre-qualified

60+ & \$12m

Staff numbers & project capability



Construction Modelling and detailing

Low Risk

Risk minimisation is paramount to us. We ensure that our systems and procedures are sound and robust. Being accredited for Quality, Safety & Environment as well as Pre-Qualification for industry groups such as NSSCS to an impressive CC3 level, ensures we maintain the high standards that you expect and that we have set for ourselves. Continuous Improvement utilising project debriefs and being dedicated to then developing the most efficient preventative systems allow us to move the wheel of progress without slipping backwards.

We have a dedicated management representative working to ensure all Policies & Procedures reflecting current work practices. We are extremely proud of the way we “choc the wheel” which ensures that our Risk Management Policy is relevant & impactful.

"We have a **passion** for what we do, the prospect of building something like a complex pedestrian bridge gets us **very excited**"



Jeremy Hawkes,
Director of Business Development



SAFETY

We work together to ensure we are safe.

We have developed a system that unlocks the combined energy of a highly engaged hazard committee. We remain focused on proactively reducing the risk of injury to all of our staff, and indeed anyone that visits our facility or works with us on our site or our customer's site.

“ Working with clients such as McConnell Dowell, OZ Minerals, DIT & TfNSW have seen Bowhill Engineering build QA systems 2nd to none. Clients love our accuracy & timeliness of our documentation and the surety in risk reduction.”



Jodie Hawkes
CEO



SAFETY

WHSE STATISTICS UPDATED MONTHLY

Includes LTIFR (Lost Time Injury Frequency Rates)

- ISO 45001: 2018 Safety Management System
People matter, so we provide a consistent approach to assess and reduce risks
- Safework SA Awards: 2012 High Commendation for “Best workplace health and safety management system”
- National Award: 2012 “outstanding Site Award” Australian Steel Institute

Lost Time Injury Frequency						
	One Day 20-21	One Day 21-22	One Day 22-23	One Day 23-24	One Day 24-25	Rolling 5 year Average
TRIFR (JMH for BHP)	= Individual Stats/Individual Stats/IG3					
Fatalities	0	0	0	0	0	0
LTI's - one day or more	15	4	10	5	1	7
Medical Treatment	17	12	29	22	1	16
Recordable Injuries	29	39	42	35	1	29
# Employees	39	52	60	60	60	54
# Days	240	240	240	240	240	240
# Hours	8	8	8	8	8	8
Total Man Hours	74880	99840	115200	115200	115200	104064
LTIFR (Frequency Rate)	20.0	4.0	8.7	43.4	8.7	17.0
LTIFR Industry Benchmark	35.1	35.1	35.1	35.1	35.1	35.1
LTI Boweng Target	0.0	0.0	0.0	0.0	0.0	0.0
Duration Rate	15.0	5.0	62.0	70.0	8.0	32.0
RIFR (Recordable Injury Fr	38.7	39.1	36.5	30.4	0.9	29.1
TRIFR	42.7	16.0	33.9	23.4	1.7	23.6
IISI	200.3	40.1	86.8	43.4	8.7	75.9
Prosecutions	0.0	0.0	0.0	0.0	0.0	0.0
Improvement notices, fine	0.0	0.0	0.0	0.0	0.0	0.0



ESG

Environmental Social Governance Framework

Our facility is located on the beautiful Murray River in South Australia. Our passion is to not detract from our environment, we are committed to reducing our impact.

We have committed to our Sustainable Energy Transition (SET) and use our ESG Governance Framework to monitor our progress.

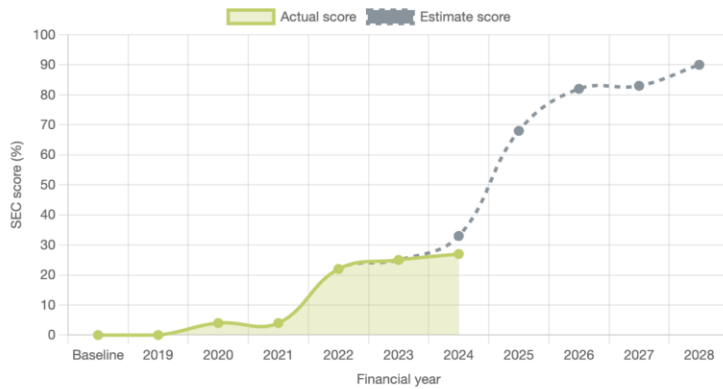

Commitment to SUSTAINABLE ENERGY TRANSITION

Shell's Commitment to Sustainable Energy Transition (SET) is a key element of our overall ESG strategy. It is a commitment to reduce our greenhouse gas emissions and to transition our energy portfolio to low-carbon energy sources.

The SET includes a commitment to:

- Reduce our greenhouse gas emissions by 15% by 2025 and 35% by 2030.
- Invest in low-carbon energy sources, including renewable energy, energy efficiency, and hydrogen.
- Support our customers in their energy transition through our products and services.

Shell's commitment to SET is supported by our Sustainable Energy Transition (SET) Strategy, which is a key element of our overall ESG strategy. It is a commitment to reduce our greenhouse gas emissions and to transition our energy portfolio to low-carbon energy sources.

Shell's commitment to SET is supported by our Sustainable Energy Transition (SET) Strategy, which is a key element of our overall ESG strategy. It is a commitment to reduce our greenhouse gas emissions and to transition our energy portfolio to low-carbon energy sources.



ESG Video Case Study



COMPLIANCE

**We do things the right way, every time.
No exceptions.**

We're immensely proud of the fact we've embedded compliance into our culture. This dedication to doing things the right way for our staff, our clients, and our environment is how we're able to point to a track record in quality, safety, and environment that's unmatched in our industry.

"Bowhill Engineering's commitment to its Integrated Business Management Systems including Safety is by far the best that I have seen in a small/medium manufacturing business. Its commitment to process compliance via a sophisticated document management system that is easily accessible to all stakeholders is commendable.

Darren Lea
Director, Perpetual Results Australia

ISO9001: 2015 Quality Management System
Provides certainty and reduces risk, ensuring a professional system for every process

ISO45001: 2018 Safety Management System
People matter, so we provide a consistent approach to assess and reduce risks

ISO14001: 2015 Environment Management System
We care about where we live and want to ensure our environmental footprint is minimal

AS5131: 2015 Steelwork Compliance Australia (SCA)
Construction Category 3 Industry regulated to ensure quality compliance of structural steel fabrication and erection

AS3834.2 Weld Australia – Cert No. AU 087 Rev 0

TfNSW National Prequalification – Dec 2021

Building Work Contractor Licence registration details for construction and building works





Together we Thrive



BUILDING FUTURES, NOT JUST STRUCTURES

Bowhill Engineering has partnered with Wildu Industrial Services, South Australia's leading Aboriginal-owned project delivery provider, to launch a new Aboriginal business and social ecosystem - designed to deliver real economic empowerment, not token engagement.

More info - www.boweng.com.au/wildu



This Australian-first model:

- Delivers projects at commercially competitive rates
- Reinvests profits into Aboriginal communities
- Supports Aboriginal business ownership and self-determination
- Creates career pathways in trades, logistics, and management
- Requires no grants, gifts or charity - just capability and commitment

**We're not just reimagining engagement.
We're delivering generational impact.**



SUCCESS



Australian Government



AUSTRALIAN TRAINING AWARDS



SMALL EMPLOYER OF THE YEAR

GOLD RECIPIENT

#ATA2025

AUSTRALIA'S LEADING CIVIL CONSTRUCTION MARKET

EARTHMOVER & CIVIL CONTRACTOR AWARDS 2015



THE AUSTRALIAN BUSINESS AWARDS

ABA100

EMPLOYER OF CHOICE WINNER 2024



2015 South Australian Regional Awards

WINNER Large Business



HALL OF FAME

2019 Inductee

FBA Family Business Awards

2019 Telstra Business Awards Finalist

South Australia Medium and Making Waves

#TelstraBizAwards



World Australia

2014 FIELD NO EXCELLENCE AWARD

WINNER

Company of the Year



Member of AUSTRALIAN STEEL INSTITUTE



AUSTRALIAN BUSINESS AWARDS

2014 WINNER

OUR LEADERSHIP



Jeremy Hawkes
Director Of Business
Development
jeremy@boweng.com.au
0417 868 356



Jodie Hawkes
Chief Executive Officer
jodie@boweng.com.au
0438 704 229



Tom Dennis
General Manager
tom@boweng.com.au
0403 567 641



Samantha Krollig
HR Manager
sam@boweng.com.au



David Holland
Senior Project Manager
david@boweng.com.au
0439 310 637



Ben Quinn
General Manager Quality
ben@boweng.com.au



Kristian Livolsi
Advisory Council (Chair)
kristian@kristianlivolsi.com.au



Jason Clark
Advisory Council
jason.clark@symonsclark.com.au



Phil Cornish
Advisory Council
phil@bellrockeng.com.au



Adrian Fahey
Advisory Council
adrian.fahey@gotosage.com

OUR TEAM



Joe Meyer
Project Manager
joe@boweng.com.au



Justin McLean
Project Manager
justin@boweng.com.au



Tyler Hansen
Workshop Team Leader



Andrew Holland
Project Assistant
andrew@boweng.com.au



Ethan Klemm
Draftsman
ethan@boweng.com.au



Reece Cockshell
Estimator
reece@boweng.com.au



Tyler Martin
Welding Supervisor



Chelsea Haby
Project Administration
chelsea@boweng.com.au



Leigh Tobin
STF Team Leader



Lauren Gladigau
Trainee Administration Assistant
lauren@boweng.com.au

OUR TEAM



Rasadari Rathnayake
Account Manager
accounts@boweng.com.au



Zoe Hawkes
Administration Assistant
zoe@boweng.com.au



Demi Hermann
Project Administration
demi@boweng.com.au



Courtney Brown
HR Coordinator
courtney@boweng.com.au



Josh Forge
CNC Lead
josh@boweng.com.au



Cheyenne Gladigau
WHSE Coordinator
cheyenne@boweng.com.au



Brad Attwood
STF Manager
brad@boweng.com.au



Tia-Jae Conway-Jaensch
Administration Assistant
Tia-jae@boweng.com.au



Matthew Smart
Materials Coordinator
matthew@boweng.com.au



Anthony Howie
Production Manager
anthony@boweng.com.au

OUR TEAM



Silvia Theron
Project Administration
silvia@boweng.com.au



Patrick Eggers
Project Administration
boweng@boweng.com.au



PROJECT HISTORY – REFEREES

Project Name	When	Project	Referee
T2D Steel Tunnel Segments	2025-26-27	Construction of 756 maintenance and emergency access cross passage tunnel opening segments. Measuring Approximately 4 meters high 2.5 meters wide per segment 5,000t	T2DA Andy Raine 0436 405 326
Dampier 2 Structural Skids	2025-26	Pipe skids for Rio Tinto Dampier 2 Desalination project 160t	OSMO Ajinkya Thubri 0422645912
T2D Structural Steel Bridge	2029	Various steelwork packages for T2DA, 1,800t	T2DA Nigel Hird 0417 167 425
MCD Sheet Pile Painting	2026	Mods and painting to sheet piles 3t	McConnell Dowell Aaliyah Teav 0417 941 508



PROJECT HISTORY – REFEREES

Project Name	When	Project	Referee
Morgan Slip Way Steel Work	2025	Headstocks, Pile Sleeves and Rails to replace the existing slipway steelwork 40t	Maritime Construction Jordan Grey 0413 916 816
Temp Towers for SRTO Arch Bridge	2025	Temp steel work - headstocks, restraints, landing shoes for arch bridge installation 60t	TGSP JV Grant Case 0401 697 224
B2A inland Rail Bridges – Short Street, Wandong	2025-26	Supply of 1 bridge for use by motorists and pedestrians at 2 different locations in Victoria, Short Street and Wandong around Broadford. 650t	John Holland Mitch Burns 0473 582 750 Theodor Ioannidis 0427 335 036
AWD Cape Cradles	2025	24 plate steel trestle extensions and associated bracing 200t + an additional 10t for other works	ANI
ANI Hoist Frames stiffeners	2025	Welding of stiffeners onsite into existing hoist frames	Paul Shinks 0427 237 455
ANI Sheave Lifting tool	2025	Small SHS lifting frame	
ANI Ship Cradle Support Trestles	2026	23 of Fabricated plate girders 14m long tapered with lots of stiffeners (14.4t ea)	
ANI Sliding Bilge Block Frames	2024	Additional batch of Keel Support frames to match PR 1333	
ANI Vessel Support Trestle Repairs	2024	Repair of damaged trestle and repainting to new colour	



PROJECT HISTORY – REFEREES

Project Name	When	Project	Referee
Light River Bridge Replacement	2025	Creation of 3-piece girders with intermediate beams 1780mm Deep x 650mm Wide x 28m.	BARDAVCOL Adam Yates 0438870341
Type C VMS Sign Structure	2024-25	Design and construct of a Type C VMS sign structure to be located in the centre of the Highway	SAGE David Natale 61427649543 Eric Skelton 61400575997
Sealink Ramps and Support Structures	2024-25	Roll on Roll off Ramps, support structure and Retaining wall steelwork for both Penneshaw and Cape Jervis. Used to load vehicles on and off the Sealink Ferries.	MCMAHONS Kurt Lindner 61 409 831 327 Ehab Sayagha
KI Ports VPA Steelwork	2024-25	Wharf terminal, fabricated truss box section, gangways steelwork along with various other components.	MCMAHONS Aaron Peterson 61 419 494 416 Nicholas Shepherd 61451996245
Sliding Bilge Block Frames	2024	A second batch of Keel Support frames to match a previous set we had done for the Client	AUSTRALIAN NAVAL INDUSTRY Paul Shinks 61 427 237 455 CMDR Jon Robarts 0415 584 402
KI Ports Temporary Steel	2024	Temporary Drilling platforms to assist in the Cape Jervis Fery port pile hole drilling	MCMAHONS Peter Tan 0488 744 221



PROJECT HISTORY – REFEREES

Project Name	When	Project	Referee
Cape Cradles	2024	CC2 – Cradles for transporting ships off shiplifters in Northern Territory 294t	WALLBRIDGE GILBERT AZTEC Rodger Weste 0439387941
Majors Road	2024	CC3– 20, 3 piece custom welded beams (10 @ 31m and 10 @ 25m) 200t	ACCIONA Ryan Favell 0400519348
Churchill Road Crane Gantries	2024	CC2 – 950m of Crane Runway Beam supplied, delivered and installed 140t	MCMAHONS Zeeshan Awan 0423806457
Shiplift Hoist Frames	2024	CC3 – 4 hoist frames with Complicated fabrication and significant post weld machining 7t	MCCONNELL DOWELL Luke Veloudos 0477683957
Mt Derrimut – MG4 - VIC	2023	CC3 – Rail Bridge 45m long through girder bridge spans x 2 of 91t	WESTERN PROGRAM ALLIANCE Grant Case 0401697224
Breakout Creek 3 Elevated Walkway	2023	CC2 – Elevated curved walkway 109m x 2.5m wide Walkway Panels with Balustrade in Apex Park/River Torrens/Karrawirra Pari 45t	BARDAVCOL Adam Yates 0438870341
Bridgewater Bridge Temporary Works - TAS	2023	CC3 – Steelwork for the construction of temp bridge under the permanent bridge (headstocks and bracing only) 623t	MCCONNELL DOWELL Toby Cuthbert-Ashmore 0401 699 261
Breakout Creek 3 Lower Level Crossing	2023	CC2 – stick steel Two short pedestrian bridges over a creek 15t	BARDAVCOL Adam Yates 0438870341
Fabrication and Delivery of Viewing Platform	2023	CC2 – Fabrication & Delivery of Viewing Platform Structures (5) 5 6180mm x 2590mm (3 with balustrade, 2x without), 9.7m rusted steel edging 8t	BARDAVCOL Adam Yates 0438870341
Ship Lifter Steelwork	2023-24	CC3 – transfer beams Lloyds compliant 200t	MCCONNELL DOWELL Luke Veloudos 0477683957
ANI SPMT Tracks	2023	CC3 – wheel load bearing structural modular deck plates 233t	MCCONNELL DOWELL Luke Veloudos 0477683957
Cooltong Pump Station	2023	CC2 - 35m long x 12m wide Structural Steel 115t	MARITIME CONSTRUCTIONS Jordan Gray 0413916816
Heysen Tunnel Sign Upgrade	2023-24	CC3 – 8 of various style sign gantry structures 70t	MCCONNELL DOWELL Deanna Milano 0419149514
ANI Pedestrian Bridge	2022	CC3 – 2x 1.8m deep custom fabricated 3 piece beams 45t	WILLIAMS METAL FABRICATION Peter Williams 0402015652

PROJECT HISTORY – REFEREES

Project Name	When	Project	Referee
Sydney Gateway SB91 & SB61	2022-23	SB91 – 1x girder, 75m long, 100t, SB61 – 5x girders, 75m long, 671t (RMS TfNSW)	John Holland Seymour White Ray Chow 0400 956 330
Prominent Hill – Head Frame	2022-23	2.5m diam columns, 60m high, trial assembly of 300t with a total of 650t	OZ Minerals (now BHP) Charlie Fearon 0437 215 459
Ovingham	2021-22	16 Bridge Girders – 1400t, Temporary Works (CC3)	McConnell Dowell Glynn Thomas 0455 319 185
Granite Island Bridge Temporary Works	2021	400t of temporary steel supplied	McConnell Dowell Jan Sibert 0416 876 565
Coopers Creek Bridge	2021	1x span, 30m long weighing 32t over the Coopers Creek	Bridge & Marine Wayne Smith 0429 363 745
Regency to Pym	2020-21	20 Bridge Girders – 1500t Pym Street Pedestrian Bridge – 64m long – 110t (CC3)	McConnell Dowell Nigel Hird 0417 167 425
Gawler River Rail Bridge	2020-21	2x Through girders 28m long, 19x cross beams, 18x bracing tubes	Bardavcol Adam Yates 0438870341
Flinders Link	2019-20	20 Bridge Girders – 1500t Temporary Works (CC3)	Gateway South Jordan Bloxham 0477 356834
Snowy 2.0 Bridges	2019	Yarangabilly & Wallace Road Bridges (CC3)	LEED Shane Burke 0400 166 440
Williams St Bridge	2019	2 x Through Bridge girders, 2 header beams & 36 cross beams (CC3) - 350t	Rail Infrastructure Alliance Anthony Baldi 0455 783 143
Oaklands Crossing	2018-19	Pedestrian Bridge & Canopy - 190t	PTPA Adam Downie 0427 716 554
Darlington Upgrade	2017-18	2x 180 dual lane road bridges – 1100t Extensive temporary works	Laing O’Rourke Nigel Hird 0417 167 425
Southern Expressway Duplication	2012-14	3x road bridges, 5x pedestrian bridges, sign gantries	Lendlease Kevin Shine 0418 932 517
Wayville Train Station Pedestrian Bridge	2013-14	50m long geometrical pedestrian bridge & lift tower	McConnell Dowell Nigel Schmidt 0419 037 551

“

Bowhill Engineering has always demonstrated outstanding communication whether it be complying with contractual obligations or conveying engineering solutions to enhance the overall project directives and timelines. Respect for our clients views and requirements have always been met with positive enthusiasm even when dealing with difficult or demanding circumstances. Their QA and safety systems are very mature and it is clearly evident that they take seriously their commitment to safety and quality, in both action and documented processes...

Mark Osborne
Business SA Advisor

COMPANY DETAILS

Trading Name: Bowhill Engineering

Registered Address | Principal Place of Business

68 Weber Road
Bowhill SA 5238

Bowhill Engineering Pty Ltd ITF Hawkes Family Trust

Registered: 2/5/1995

Licensing and Business Registration

ACN: 069 189 519
ABN: 33 911 388 370

Contractor Licence # BLD 166373

Workcover

Policy Number: E13282201

Public Liability Insurance

Company: Fully Insured/Lloyds of London
Policy Number: B1881B230322-C17001049
Amount Insured: \$20,000,000

Bank Details

Bank: Commonwealth
Branch: Murray Bridge
BSB: 065-505
Account No: 1003 3714
Account Name: Bowhill Engineering P/L

TRADE REFERENCES

Brice Metals

08 8405 7111 GordonS@brice.com.au

Ferrocult

08 8130 0600 srowle@ferrocult.com.au

Konnect Fasteners

08 8300 8700 Daniel.Herbert@konnectshop.com

Korvest

08 8360 4548 George.Elvin@korvest.com.au

United Fasteners

08 8311 2999 jake.adey@unitedfasteners.com.au



FACILITIES & EQUIPMENT

- 2,000 m² – Main Workshop Assembly 25m span open layout for larger components
 - 2 x 20t Overhead gantries
- 1,500 m² – 23m High Heavy lift workshop 20m span
 - 100t overhead gantry with 16m hook height. 2 x 30t overhead gantries
- 1,000 m² – Assembly Workshop
 - 3m wide, 6.5m long and 2.2m high double column machining center.
- 1000 m² Surface Treatment Facility:
 - Surface treatment undercover area is insulated and climate controlled
 - Blast chamber 8.1m wide – widest in SA (capable of coating 70m long items undercover)
 - 4 blast nozzles at once via a 6t Mega Blast Pot
 - EPA approved
- 400t+ of Temporary Steel, 20,000 m² of Onsite Storage with 5+ acres of hard stand area (6.7 hectares – total landpackage)
- Onsite lifting equipment:
 - 1 x 33t capacity forklift, 1 x 16t, 1 x 7t, 1 x 6t, 2 x 4.5t, 1 x 3.5t and 4 x 2.5t
 - 2 of 90t heavy duty engineered jinker units complete with hydraulic lifters on each unit
 - Movement of up to 140t items on site can be achieved easily and storage onto our large range of rated trestles for easy loading onto road transport.



FACILITIES & EQUIPMENT

- **Heavy Lift Truck Trailer combination:**
 - Subcontractor; intra and interstate movement of up to 65m long, 150t, 5m wide 6+m height segments
- **CNC Machining Centre**
 - Okuma 6.5mx2.5m double column machining center (Jan 2026)
- **Welding equipment (Mig Welders):**
 - 3x Robots - IGM 7 axis rotating arm, twin wire, Fronius, 5m vertical clearance & 60m rail length, laser cameras (Jan 2026)
 - Lincoln, Esab, WIA, CIG Mig welders, all 500a with remote wire feeders
 - 2 x sub arc welders 1000 Amp (Lincoln, Esab)
 - 2 x Shear Stud Welders (Soyer/KDC up to 22mm diameter studs)
- **Temp steelwork for modification and hire:**
 - Large road frames and crane mats
 - Bridge support towers (for use with SPMTs)
 - Spreader beams, headstocks, props
 - Formwork, sand jacks, temporary bearings, packers, etc.
- **400KW Diesel Engine Back Up Generator:**
 - Cummins back up generator capable of running whole site during power outages.



B5 – HIGH BAY HEAVY LIFT WORKSHOP

Bowhill Engineering have invested heavily in our fabrication capability with the building of our largest capacity workshop ever, opened Feb 2025

- 100t main gantry – 16m hook height
- 2x 30t gantries – 12m hook height
- 70m long, 20m wide, 23m tall
- Door opening 12m high, 13m wide end doors
- 600amp electrical supply
- 500kva backup generator

B5 – 3X IGM ROBOTIC WELDERS

IGM RTE 497-S; 7 axis with rotating arm and standard wrist joint, nominal working radius 1.900mm,

5m vertical clearance & 60m rail length, laser cameras



B2.2 CNC MACHINING CENTRE

- Okuma MCR-A5CII
- 30 x 65 Double Column Machining Centre
- Next generation OSP-P500M CNC Control



Image above for general reference only

Specifications:

Travels

X axis	6,700mm
Y axis	3,600mm
Z axis	800mm
W axis	1,200mm + 600mm Ext option
Effective width between columns	3,150mm
Tabletop to spindle nose	0 to 1,850mm + 600mm Ext option

Table

Max working surface	6,500mm x 2,500 mm
T-slots	24H7 x 13 @ 200 centres 180 from side face
Distance from floor to table	170 mm std in floor installation
Height from machine bottom to	900mm
Max load capacity	43,000 kg



CAPABILITY STATEMENT

Bowhill Engineering is an innovative structural steel engineering firm with specialist capability in large complex steel structures.

Founded in the early 70's, for the past 50+ years Bowhill has developed an enviable track-record for project delivery. Bowhill's reputation is built on:

- Specialising in large complex structural steel
- Being easy to do business with
- Offering a collaborative problem-solving approach
- High capability for developing innovative solutions
- Track record for delivery-on time and with high quality
- Price competitiveness



CAPABILITY STATEMENT

Bowhill is widely recognised for excelling at technical challenges. Their collaborative approach draws together project stakeholders driving down the risk profile to ensure successful outcomes. Their geographic location suits their core competency and allows efficient transport anywhere in Australia.

Bowhill directly employs a stable workforce of 60+ highly specialised staff, this strengthens their community and provides the ability to deliver world class innovative solutions for their national clients. The firm delivers some \$15 million worth of landmark projects annually.

Bowhill lead the way with their integrated systems and professionalism, a “boutique” firm focused on a specialisation in a very specific niche in the construction market.

Regarded as specialists in complex & heavy structural steel fabrication, particularly larger components. Bowhill have deliberately developed their core competency which has allowed them to highly progress their skills.

When coupled with their purpose-built fabrication facility complete with one of Australia’s widest blast chambers, their competency is highly sought after. This allows Bowhill to produce these challenging size projects with absolute safety and the efficiency gained translates into competitive rates.

Bowhill’s target markets include government infrastructure, mining, marine and, defence – Bowhill Engineering have successfully completed many critically important projects for these industries.

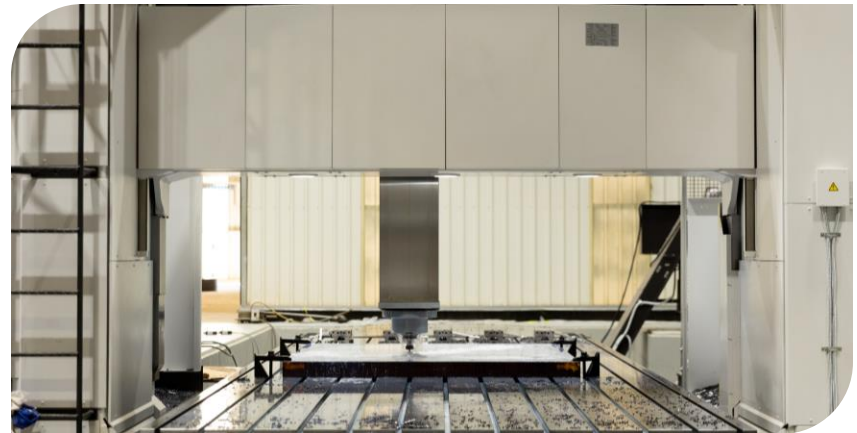

Uniquely valuable services

Bowhill Engineering have a proven track record, the many benefits to our clients are enforced by the rock solid reputation that we've built over some 40+ years in business.

Methodology Development

Our wealth of experience, innovative staff and state of the art software, well equips us to serve our customers with safe, efficient and synchronized methodologies. ECI type contracts or complex tasks that need "proving" before manufacture are common for Bowhill Engineering. 3D simulation enables us to electronically trial proposals, identifying the merit from a physical, safety and practical, standpoint.

A strong methodology development capability allows us to maximise build-ability and accuracy.



“

We do things for our
customer's convenience,
not our own

Jeremy Hawkes, Director of Business Development

Uniquely valuable services

Speed and Accuracy

Drafting using Tekla 3D software and the associated free Trimble Connect collaboration software has allowed us to achieve lean manufacture principles and error proofing through all project stages. This results in NC format files (which are developed straight from the project model) being sent via email straight to the steel merchant for CNC processing. Accuracy and speed are huge advantages resulting from this process.

Metrology

Bowhill have recently developed in-house technology to accurately measure larger items in 3D using our Trimble X12laser scanning tool. This is a survey grade machine that can also provide laser scanning to ensure accuracy via electronic comparison to the 3D model.



“

**The coating process protects
the client's valuable
investment, it must be right**

Tom Dennis, General Manager

Uniquely valuable services

Value for money

With a committed stable and experienced workforce (average staff retention rate in excess of 5 years), with a great workplace culture, productive behaviours, we are able to reliably produce structural fabrication components of exceptional quality at competitive market rates. We do this through our lean manufacturing processes as well as utilising SA's extensive industry supply chain. We manage the potential risks of outsourcing by fostering strong supplier networks and contracts.

This approach is an extremely effective way of achieving an impressive result for all stake holders on a project. Minimization of capital outlay reduces costly overheads, increases our overall capacity and benefits our clients through the resulting low cost structure. This strategic approach allows an impressive quantity of available capability, whilst allowing a nimble structure with diverse skills. This ability to be very flexible and adaptable can be applied to many different challenges and industries without compromising our core focus of heavy and complex structural steel.



“

**We do what we say
we are going to do**

Tom Dennis, General Manager

Uniquely valuable services

Reputation

We have runs on the board. By nominating us on your project team, your clients or stakeholders will be favourable to your overall proposal.

Bowhill Engineering have been active in the building and construction industry since the late 1990's. Our reputation is something that we are passionate about and something that we take great care of. As you well know, in this industry any mistakes are well known and reputations are easily damaged. Throughout this entire time Bowhill Engineering have not one tarnish on their reputation, quite a testament, and rarely seen.

Surface Treatment

A modern surface treatment facility that is specifically designed to efficiently handle large components, in an environmentally sensitive way. Our Blast room is one of the widest in Australia! The ability to complete this critically important process on our manufacturing site is hugely beneficial to you as our client because it results in savings, quality control and effective loading on transport. In simple terms we can ensure that you get what you want, when you want it! Without this in-house service other fabricators are at the mercy of the industry, and they simply do not have the control that this critical process demands.



“

We help our clients win

Tom Dennis, General Manager

Early Contractor Involvement (ECI)

Why assembling the right construction team early creates winning outcomes

Our experience tells us that there are fantastic, mutually rewarding and industry building solutions waiting to be discovered. It just requires the right approach to unlock them. We all want a competitive advantage, we all want to lower risk and increase performance and profit, could this ECI approach be the most effective way to do all of this, for all parties?

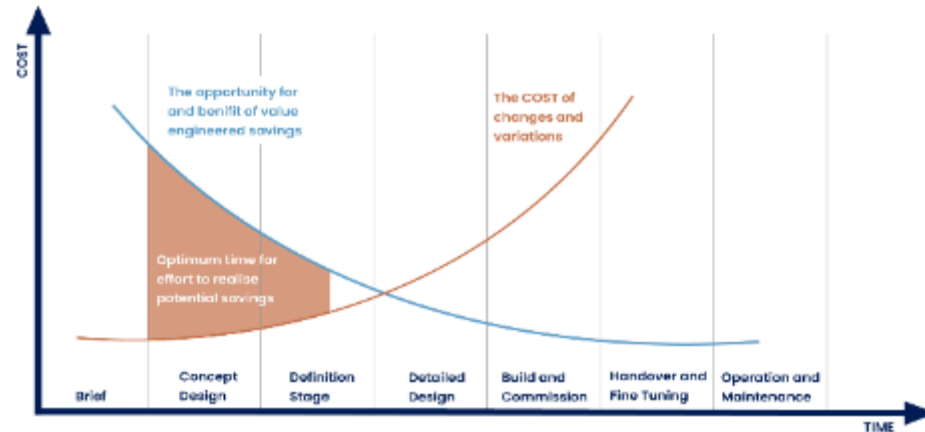

There are many positive outcomes that we have seen as a result of our involvement in this approach and they are experienced by everyone involved, not just from our perspective as a subcontractor. The next-level understanding of critical trade nuances is normally out of reach of designers and contractors because trades keep their secrets as their own IP. Sharing of knowledge helps to drive down risk, drive up smart, thoughtful and efficient design and encompass the overlapping and inter-dependent trades. Building relationships with the best subbies in the industry is a smart approach, it helps your organisation and limits your competitors access to them. Learning together and creating an inter-dependent culture where “none of us are as smart as all of us” make a strong team approach. Very hard to keep success away from a strong team! Winning, but not at someone else’s expense! Winning together! Magic can happen, industry norms can be surpassed with better more unified design that supports the whole supply chain and program.

- With the right people (experienced in diverse but complimentary ways),
- Working together to an aligned goal, where all parties can benefit from smarter solutions
- Freedom for brainstorming and challenging the status quo and inter-dependent exchange of ideas

Key Differentiators

Our ECI program will help you win before you start! We are so confident in your satisfaction that we'll refund the entire cost if it doesn't!

Bowhill Engineering have developed years of experience with regards to ECI (Early Contractor Involvement), we have the runs on the board, case studies and testimonials to clearly demonstrate how powerful the process can be. We encourage your team to check in with our referees (provided later in this document) to support our claims. If your team are looking for a specialised contractor that they can establish a **mutually beneficial sustainable partnership with a trust based and collaborative relationship** then it'd be hard to go past Bowhill's alignment to this mission!



Key Differentiators

Bowhill Engineering are a wholesome, financially solid, high performing and innovative regional 2nd generation family business, we've been around for 50+ years.

We enjoy an exceptional reputation in not only our industry, but our region and our community.

We currently employ 15 apprentices and 2 trainees, we invest in our people's future and pride ourselves on building regional leaders (1.8% of Bowhill's turnover is invested in training our awesome staff)

Our NPS (net promoter score) is world class (currently at 100) as rated by our clients. This is an excellent indicator of what you can expect of our service offering.



Key Project Success Factors

Bowhill have a good understanding of this project's criticality, our particular focus is on how we can demonstrate the following key areas.

- Capacity
- Flexibility
- Complimentary contractor networks
- Metrology/accuracy
- Off site movement and handling
- Off site storage
- Road transportation
- Heavy Plate fabrication
- Welding to high specification
- Post weld machining of heavy items
- Blast & coating of larger elements



Key Project Success Factors

Network of complimentary contractors, Bowhill have already aligned with some of the best contractors in the industry to supplement our own internal capabilities. These specialist trades when handpicked form a team with collaboration, depth and experience, it ensures certainty of outcome.

Metrology, using our total station surveying tool (that can also conduct laser scanning), given the criticality, we'll be able to complete a series of measurements that can provide absolute dimensional control over the whole process from start to the final post-fab alignment to the specified tolerance via the as-built check. Measurements are compared via a heatmap and measurement matrix from point cloud to the 3D Tekla BIM model. Freely shared amongst the construction team as required, it will bring confidence for the installation process. In simple terms, things will fit without disruptive interference or inefficiencies.



Key Project Success Factors



Post weld machining of heavy items

Bowhill Engineering has invested in one of Australia's largest double-column Okuma CNC milling machines, featuring a 2.5 m x 6.5 m bed and over 2.2 m spindle clearance. This capability supports advanced, high-precision manufacturing and provides full control when machining heavily welded thick plate components affected by weld distortion.

Robotics

Bowhill Engineering has commissioned three of Australia's tallest and most advanced robotic welding systems from IGM Austria. Operating on a 60-metre track with nearly five metres of clearance, this installation ranks among the largest robotic welding stations in the country.

Featuring laser cameras, seam sensing, and 3D model programming, the system delivers exceptional accuracy, repeatability, and reliability. Twin-wire welding capability enables high deposition rates suited to demanding structural applications, including bridge girders and heavy platework.



Key Project Success Factors

Heavy Plate Fabrication is what we do, it's Bowhill's speciality, we have been working with high spec, thicker plate projects exclusively for many years. Weld procedures, stress relief, heat distortion control, material testing and grade selection, NDT frequency as well as choosing the most effective type of testing are common considerations for Bowhill's team. We have a many examples of similar projects, this work is not new for us, we have demonstratable experience to complete this work with confidence.

Welding aligned to high specification requirements has become a smooth process within our QA, project and production teams. We run a process that we call "technical review" so that we as a team clearly understand the requirements within the engineering specification and to ensure that we provide complete compliance to that requirement. Even before we submit a tender response we have a detailed understanding of what's required, this avoids any gaps between what's been allowed and what our clients expect.



Key Project Success Factors

Blasting and coating of larger elements is also what we do, we've been completing this scope for as long as we've been in the game. Since initial opening in 2006, we've continuously upgraded our facility to handle longer, heavier elements in a similar way to that of a ship yard. We've got an impressive facility that utilises 4 blast operators/hoses at once, this gives us the ability to completely blast large (up to 110t) elements and prime coat within less than a 10 hour period. Because we do this in house at the same facility we enjoy the efficiency of an integrated workflow and quality piece of mind.

SURFACE TREATMENT FACILITY, 70M LONG



Key Project Success Factors

Transportation and handling of larger elements is par for the course at Bowhill Engineering. We have developed safe and efficient processes to construct and move larger elements around at our well equipped site. Significant investment has been made in our jinker trailer and trestle system to seamlessly move up to 140t segments using our own staff and equipment. This process can also be adapted to work with great effect at your site using SPMT modules if deemed appropriate.

Free off site storage at Bowhill's facility is not a problem in the event that completed elements need to be staged prior to site install.

Road Transportation of the finished elements is an area that is well catered for at Bowhill Engineering. Specialised solutions utilising temporary steel or custom designed and engineered bolsters are options for the safe movement of the transfer beams. Heavy vehicle route from Bowhill to almost anywhere in Australia has proven to be successful and we would expect no issues when the time comes for delivery.



SX-12 Robotic Total Station

The SX12 is a robotic total station with scanning capabilities, meaning we can use it to achieve high accuracy measurements as a total station, but also use it as a point cloud if required for a project. This model gives additional functionality to the user.



SX-12 features

Together we Thrive



**Autonomous
design**



**Total - station
survey**

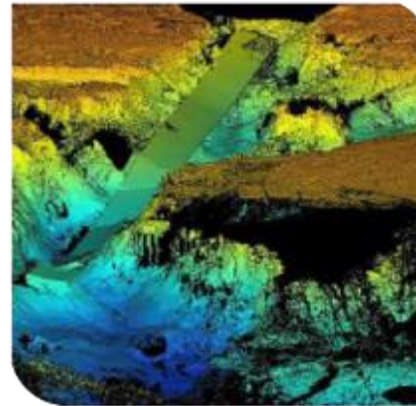

**Point cloud
scan**



**Post - scan
measurement**

Case Study

OZ Minerals Headframe

67m Tall

53m Legs

4 parts – 30T each

2.4m Diameter pipe

1.6km Cable length

2x 30T ore buckets

60kmph

400T UPPER ASSEMBLY





bowhill
engineering

Together we Thrive

Case Study



A-frame trial assembly

Case Study

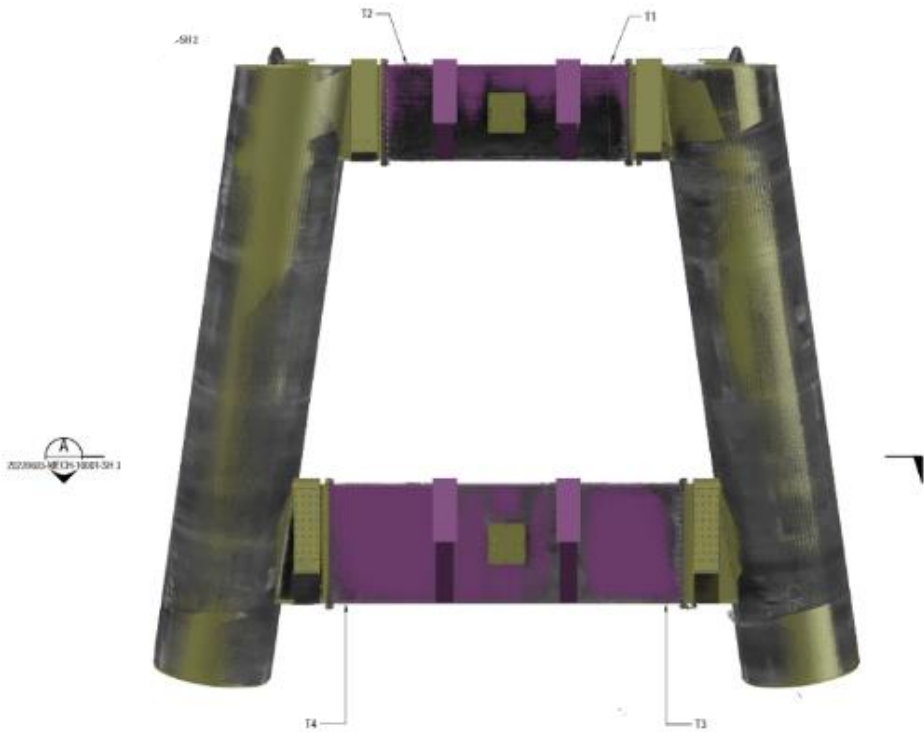

SX-12 Robotic total station



Case Study



Completed upper legs

Case Study

After going out to the market in the search of suitable contractors for this significant structure, we were pleased to find Bowhill Engineering. Their bid was compelling not just in terms of price, but especially in their ability to meet the RFQ's evaluation criteria. Since awarding them the contract we have built a solid relationship and have been very impressed with the work they are doing and the way they go about their business

Eric Downing | Project Director – Prominent Hill

Completed Head Frame Structure





bowhill
engineering

Together we Thrive

Case Study



Key learnings

Digital data collection

- Due to the large quantity of connections, traditional measurement processes were not satisfactory.
- Point cloud data was not applicable for data interrogation.
- New technology was implemented from various recommendations.
 - Point cloud data
 - Total station measurement
 - Flatness survey

Heat distortion

- Because of the large plate size for box beams / Can connections, heat distortion couldn't be fully controlled.
- Machining was needed to return distortion to a full contact flat face.
- Machinists needed clear and accurate data to complete their scope accurately.
- In-Situ machining has not been regularly done at Bowhill Engineering prior.

Case Study



Back to back assembly – distortion control

Case Study

Despite distortion control,
50 plate full penetration welding from webs/flanges
to connection plate still pulled face out of tolerance

		C18 - B10										
		SURVEY FROM MACHINED SURFACE										
		MAX	-									0.28mm
		MIN	-									-5.06 mm
		Standard deviation	-									1.81 mm
		LINE B										
0	X	215	430	645	860	1075	1290	1505	1720	1935	2150	
Y												
	104	-1.38	-3.30	-3.05	-2.81	-2.93	-3.43	-3.61	-3.16	-2.11	-0.35	-2.81
	329	-2.82	0.37	0.08	0.28	0.09	0.03	0.00	-0.25	-0.17	0.00	4.39
	493	-3.61	0.44								-0.07	-2.06
EDGE C	657	-3.94	0.46								0.07	4.66
	821	-3.04	0.42								-0.11	-0.00
	986	-2.07	0.70	0.57	0.25	0.47	0.31	0.01	0.08	0.05	0.00	3.24
	1150	-1.35	-1.70	-3.46	-3.52	-4.15	-4.15	-3.80	-2.84	-0.89	0.35	-1.30
		LINE D										
		ESTIMATED THICKNESS TO REMOVE TO ACHIEVE FULL FLATNESS										
		-5.06 mm										





bowhill
engineering

Together we Thrive

Case Study

Using specialised contractor TransAlign to clean up faces via a custom fabricated machining frame

Case Study

Using total station measurements to ensure that the post weld machining of the faces was true to the 3d model geometry rather than just cleaning up for a flat surface, with the potential for connector plates to be out of the correct plane.

Total Station survey of flanges



Case Study

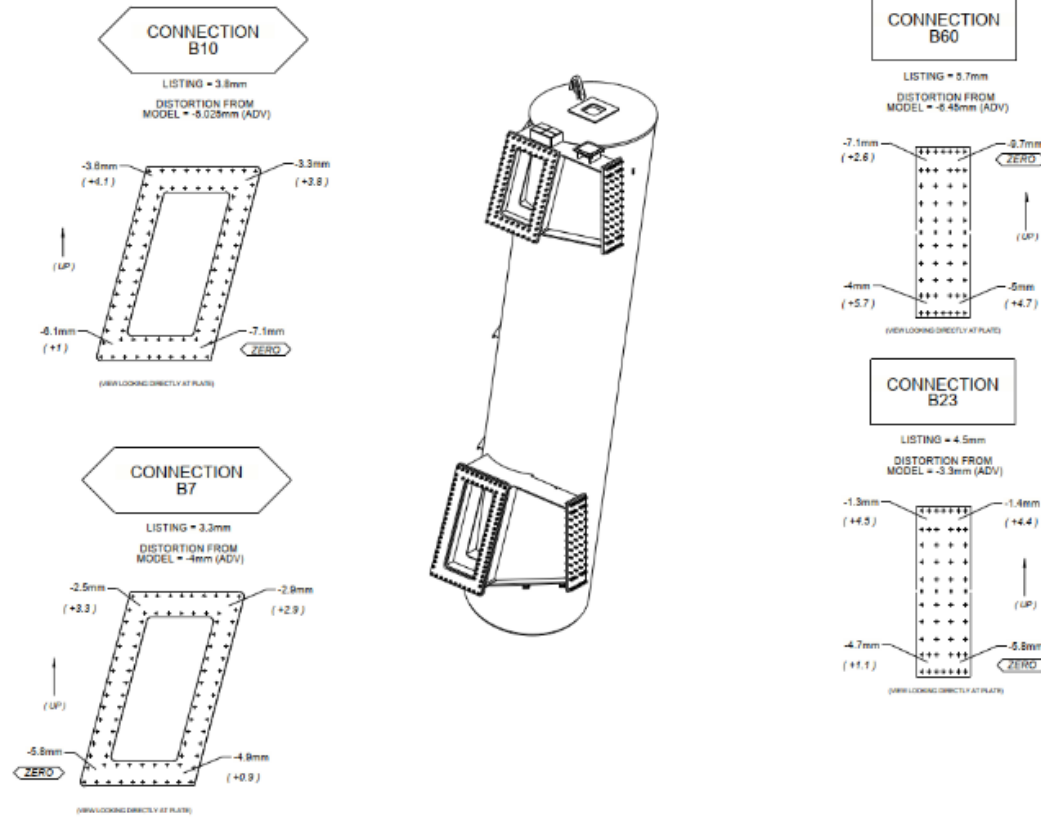

SX-12 Scanning Technology

Drawing Notes		Client	
<p>DATA IS TAKEN FROM TOTALSTATION SCAN</p> <p>ALIGNED FOR BEST FIT COMPATED TO MODEL</p>		Project: 106 - Project Name	
		Drawing Title	
		Drawing Number	
		C18 SURVEY	
Revision No.	5	Modelled By	Modelled by
Rev Date	130 138 ***	Issue Date	24.08.2022

Case Study



Insitu machining at Bowhill's facility



In situ machining at Bowhill's facility, custom fabricated support framing to suit application.

Case Study

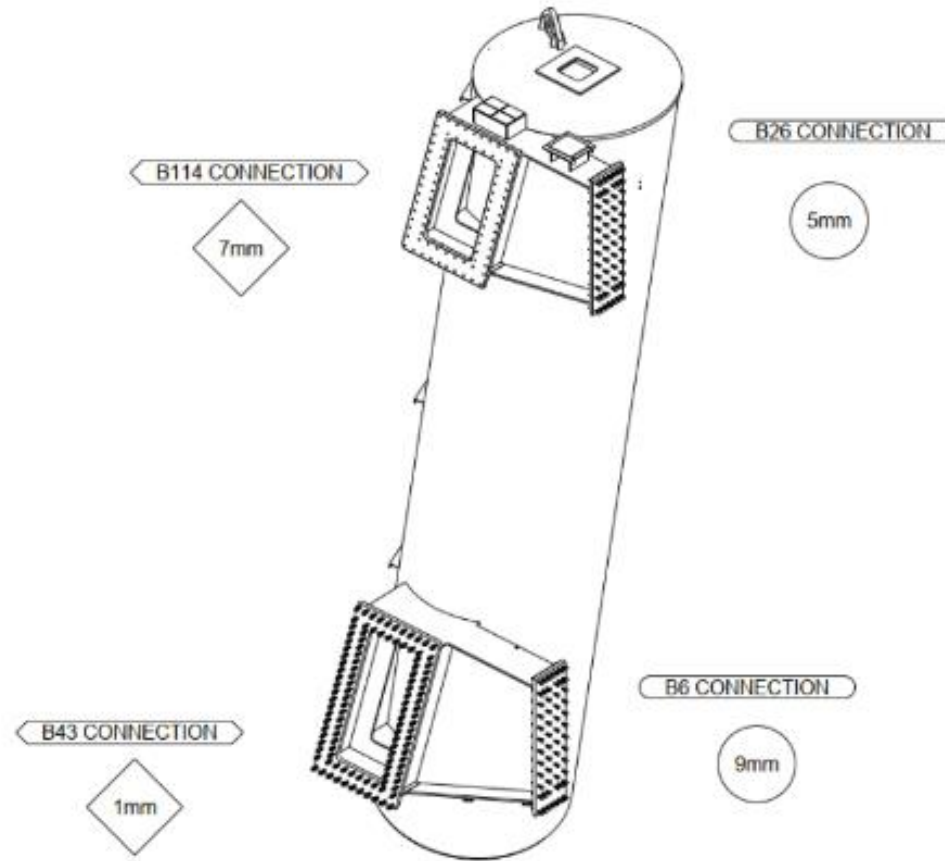

Packer thickness drawing after machining has been completed.

EARLY OPTIMISATION

Regency to Pym

Client Name: McConnell Dowell

Year Completed: 2020



Early design optimisation; helped set this project off in the right direction. The macro level trade considerations such as mill plate sheet size availability, cross section and girder length/weight limitations, weld joint design and the like were considered as early as the main contractor tender stage. Bowhill were happy to provide this early input with no obligation and extend this service to other contractors who would like macro level trade focused feedback on concept designs.

Design coordination meetings; held (mostly via video conf) at regular intervals with the whole engineering and construction team helped to avoid a lot of time consuming RFI 's and clarifications during the engineering drawings development and shop drawing/modelling stage.

Project Modelling; The collaborative nature of Bowhill's modelling process is building towards having just one coordinated shop drawing and engineering model rather than separate engineering and shop detailing processes. This we believe to be a huge opportunity to further progress towards true BIM practices and to build the coordinated process that captures many win-win outcomes for all stakeholders. It can't be understated the learning process that happens as a spinoff benefit from these collaborative discussions. The learning transfer happens across the full spectrum of stakeholders it is not one way from learned to practical as you might expect, rather even senior engineering and construction staff can gain practical insights from trade focused collaborators & visa-versa.

EARLY OPTIMISATION

Regency to Pym

Client Name: McConnell Dowell

Year Completed: 2020



Temp Works; The use of temp works on this project has been significant mainly due to the installation methodology where the majority of the bridge is pre-built, finished from insitu slab, road surface, barriers etc right up to light pole bases and then installed using an SPMT (similar to the Darlington road bridges a few years ago). In this instance, the prebuild happens some 500m from the permanent location and occurs as 2 x 1300t 84m long x 15m wide sections of bridge supported at permanent height of around 6m to underside of girders. A significant scope and with the innovative reuse of 200t of previously used steel that Bowhill have secured from previous works (+100t of new steel), we've done this work at lower cost than new steel only (\$1m for all new verses \$500k mix of new and repurposed).



IMPLEMENTED LEARNINGS

Flinders Link Railway Bridge & Temporary Steelwork

Client Name: Gateway South
(Fulton Hogan)

Year Completed: 2018-2019

20 Open top box girders for the Railway Bridge simply supported girder segments

Implementing learnings; Being the 4th steel bridge at this project site, the efficient design features that had been uncovered on previous scope packages were fed into the design development for this bridge.

This assisted with speeding up the design process and allowing cost savings to be realised by the Gateway JV during the tender period. Bowhill were active in sharing and assisting in this process and full credit to the Gateway team for pursuing this continuous learning discipline.

We believe that these initiatives are helping to strengthen the case for building steel bridges in favour of other competing materials.

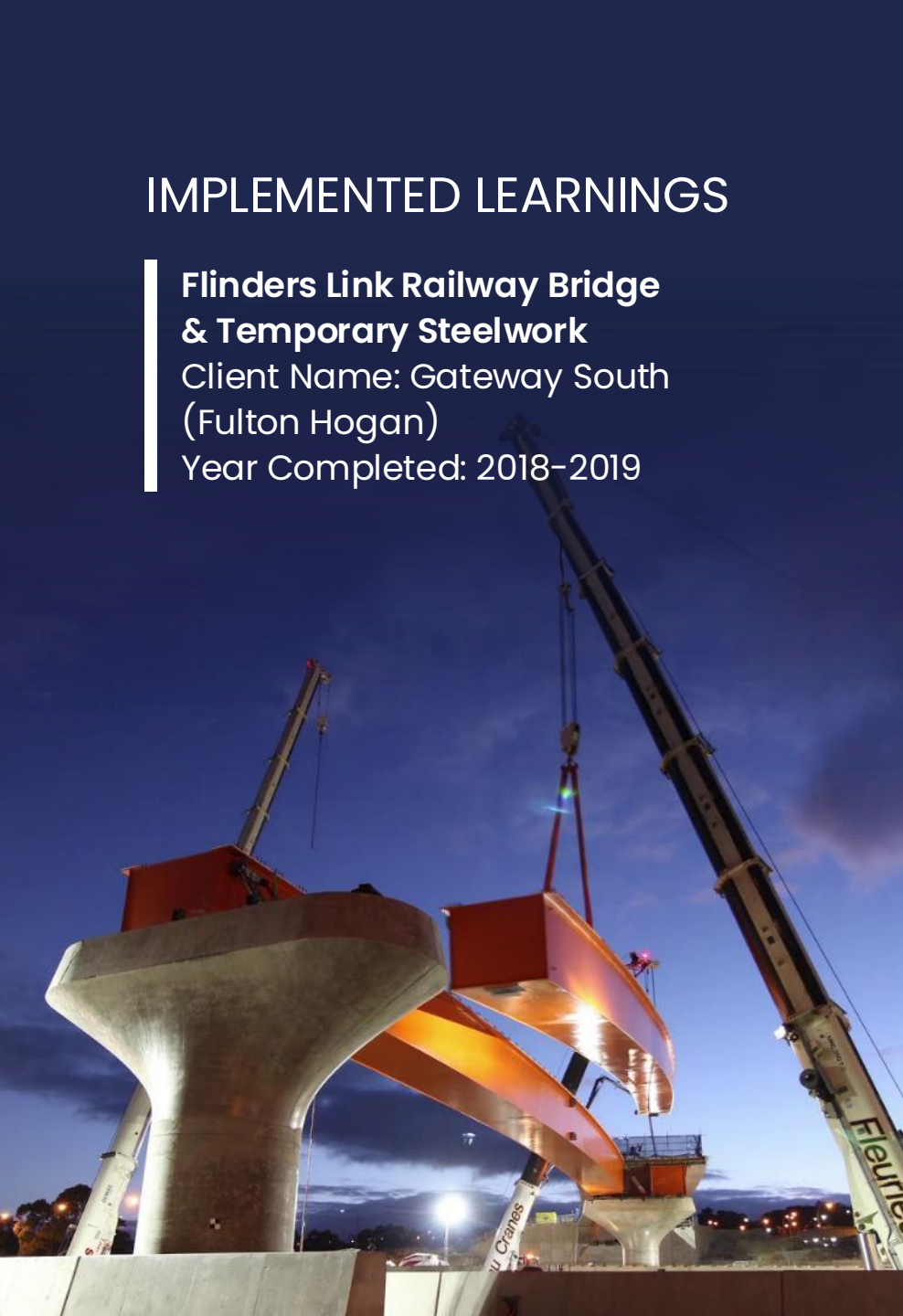

IMPLEMENTED LEARNINGS

Flinders Link Railway Bridge & Temporary Steelwork

Client Name: Gateway South
(Fulton Hogan)

Year Completed: 2018-2019

Sand Jacks; Engineers specifications increasingly state that Bridge girders are not to be installed directly onto the permanent bearings. This lends itself to an opportunity for an innovative solution.

Bowhill have been providing their inhouse IP for this solution via their modular sand jacks. These jacks can be pre-set at the required height and can accommodate the unforeseen loads during the construction process. Then once all works completed, they can be safely lowered in a controlled manner without the use of any complicated or expensive mechanical, electrical, or hydraulic assistance.

It's as simple as either blowing out the sand with compressed air or some site teams have even used a vac-truck to remove the sand and avoid any need for clean-up. We now have a range of these jack kits in stock ready for incorporation into our next project.

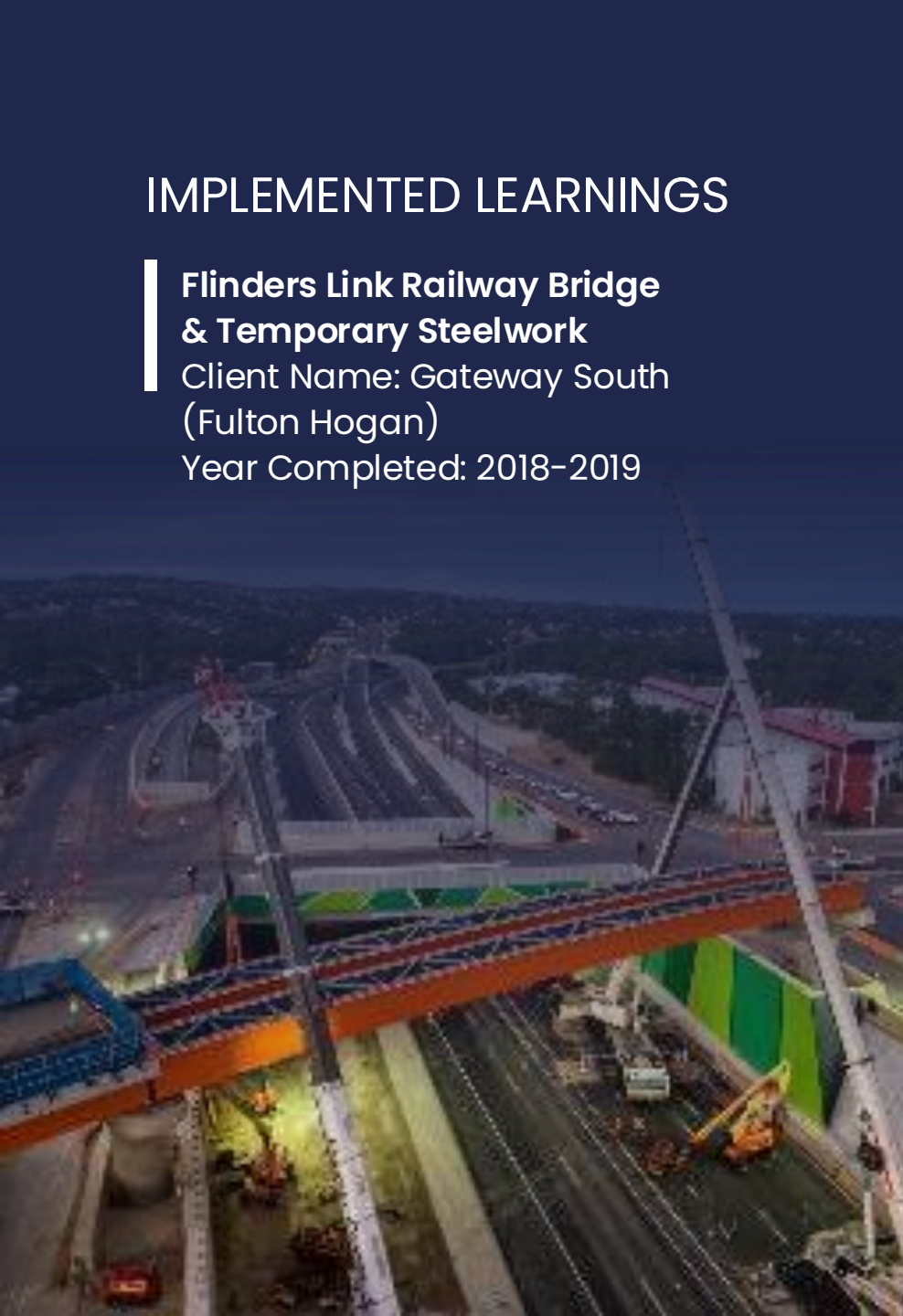

SAVED \$350K AND 4 WEEKS ON CRITICAL PATH

Darlington Bridge 3, 14 & Temporary Steelwork

Client Name: Gateway South
(Fulton Hogan)

Year Completed: 2017-2018

During the main contractor tender phase Bowhill Engineering helped our client Gateway South (Fulton Hogan/Lang O'Rourke JV) flesh out some critical constructability feasibility checks. This process was done well before award of the contract to Gateway and hence well before any contract being negotiated with Bowhill Engineering. This process uncovered some important budgeting information to allow our client certainty with their bid to the project client (DPTI). Early Engagement is something that Bowhill Engineering invite on important projects where there are genuine opportunities to find better ways to improve the scope. This service is offered without any expectation, a reliance only on openness, innovativeness, honesty and helpfulness shines through and this alone often sees us being chosen to represent our trade during the actual project.



SAVED \$350K AND 4 WEEKS ON CRITICAL PATH

Darlington Bridge 3, 14 & Temporary Steelwork

Client Name: Gateway South
(Fulton Hogan)

Year Completed: 2017-2018



Darlington Bridge 3, 14 & Temporary Steelwork

During the project Gateway asked us to provide additional scope by way of the temporary steelwork that supported the nearly 12,000t of steel and concrete prior to its installation onto the permanent piers and abutments. Upon inspection, it was found that the initial design had some inefficient features, the clients budget was looking under serious threat. With some quick and innovative thinking between the client, their engineer and Bowhill Engineering staff, the cost to actually complete the temporary steelwork was reduced by some \$400,000, thus saving the clients budget and making the ambitious timeline to supply possible. Credit must be given to the engineer James Deane-Butcher from Robert Bird Group for the cooperative and flexible nature he had to our repeated requests towards tweaking the design to achieve significant efficiencies but still to maintain structural integrity.



OFFSITE PRE-ASSEMBLY

Williams Street Bridge, South Yarra

Client Name: Railway Alliance Australia

Year Completed: 2019

Railway Corridor Challenges: Right from the start this project had some ambitious goals, being a bridge within the rail corridor in Melbourne. The window for closures to install were small and difficult to change.

This being the case the Metro Tunnel/RIA team needed the surety that everything would fit 1st time to allow the erection of the whole bridge and trans-floor slabs to happen in just one weekend.

This coupled with a very tight construction timeline leading up to the install generated a massive challenge for Bowhill and indeed RIA.

Add to this situation the requirement to pre-assemble the main elements off site (at Bowhill) to guarantee fit-up on site and the stage was set for one heck of a project.



OFFSITE PRE-ASSEMBLY

Williams Street Bridge, South Yarra

Client Name: Railway Alliance Australia

Year Completed: 2019



Bowhill's team worked big hours and adopted some innovative procedures to bring the fabrication and welding into line with the program. Next challenge was taking the main elements (some only partially completed) out of the workshop to allow the full-scale trial assembly without "burning" too much program.

Fortunately, Bowhill had only just finished the civil works for their 110mx110m hardstand extension which was available in perfect time for this significant prebuild of the 60m x 25m x 4m deep main girders.

Bowhill's CC3 compliance (NSSCS) was another big tick to the RIA project team, it also provided them the piece of mind that the systems and procedures required for bridge building were thorough and complete and would not hinder the project.

Safety/efficiency; To safely use the onsite crane's maximum allowable rating Bowhill provided the data from an in-house developed calibrated weighing system. This data extended to all larger elements and was done after surface treatment to ensure absolute data integrity and lift planning surety. We offer this service to all of our clients as a value add now.

Timing; It is testament to the whole team that the entire structure was able to be safely erected over the rail corridor within RIA's ambitious program of just one weekend.

Collaborative Model Review

Oaklands Railway Station

Client Name: McConnell Dowell

Year Completed: 2018-2019

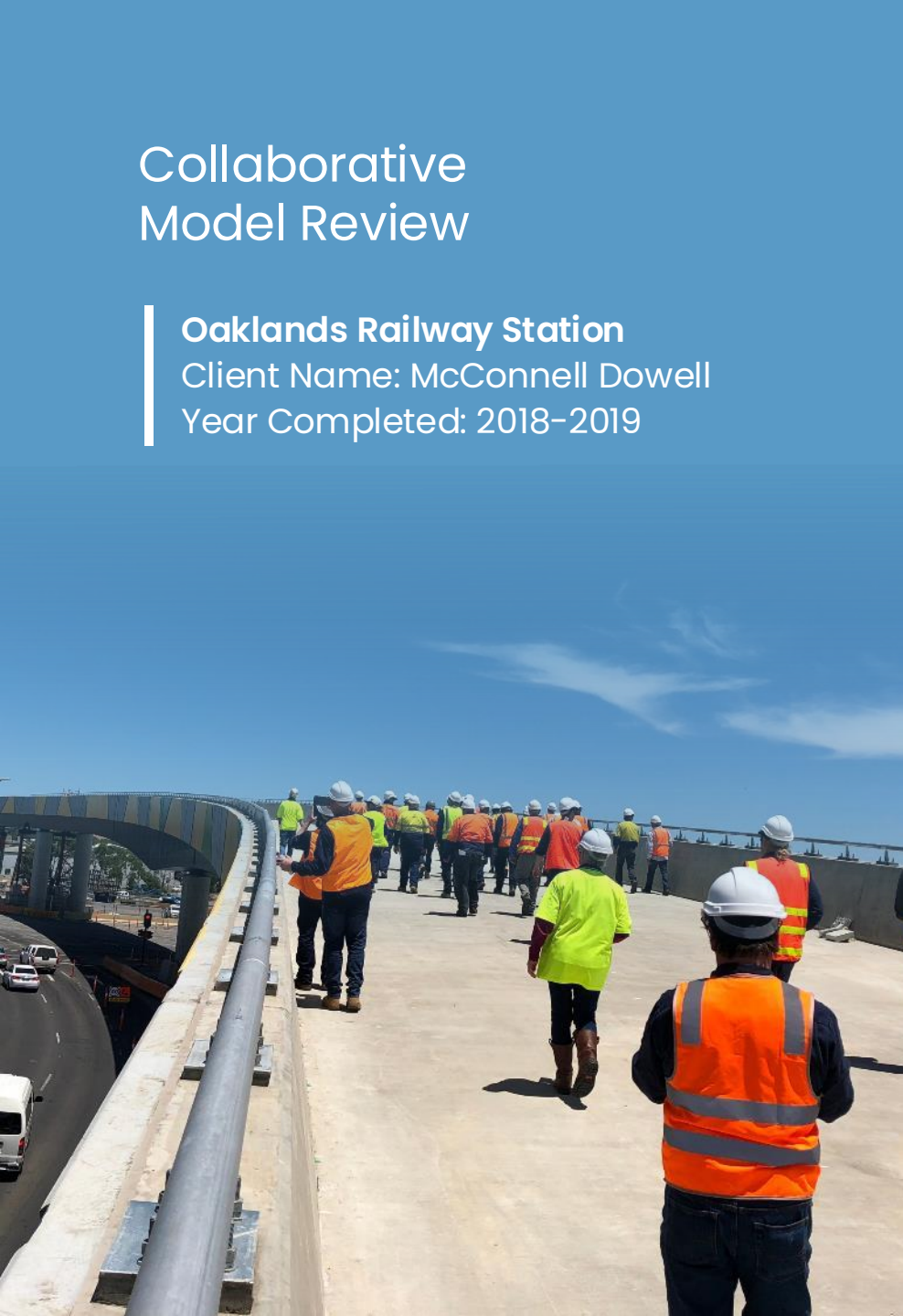

Oaklands Railway Station Project is a high profile striking architectural statement, it's also a complex structure comprising around 200 tonnes of steelwork. Our Client MCD knew it was important to get the right contractor onto the team as the project's program was of huge importance to them and their client DPTI. The success of the project relied upon an incredibly smooth run and some hard work, we knew from experience that if it was coordinated and planned right, and the total construction team were on the same page, we had every chance of producing the miracle that MCD was after.

We instigated weekly face to face meetings during the critical model development stage, attended by construction modeler, architect, engineering, MCD, DIT, ourselves and any other trade that was relevant at each stage. Boweng believe that this was the key to the project's success as issues were worked through in real time, all parties providing input allowing modeling to progress without being held back due to frustrating RFI's bouncing around in emails. However, the model wasn't just progressed, the collaborative approach saw many smart design features adopted, not from any one person's idea, but from a combination of everyone's knowledge and varied perspectives mixed into developing the final solution. We also brought peace of mind to the technical requirements due to having been CC3 certified to the NSSCS for a year already prior to starting work.



Collaborative Model Review

Oaklands Railway Station

Client Name: McConnell Dowell

Year Completed: 2018-2019



“

We opened the train station on Monday morning which was amazing to see.

Thank you for all your assistance to get to this point. Bowhill have been massive contributors to the project, delivering \$1.5m of steel fabrication.

Bowhill's input and interaction during the latter stages of the design phase provided the Project with some fabrication smarts which was of great benefit with both time and cost.

The detailing by Steve Wurst and Steve Bown was outstanding and they really took on the challenges put before them with the difficult geometry of the canopy structure.

The fabrication and coating performed at Bowhill's workshop was completed to a high quality with minimal fuss and any hiccups were dealt with by Bowhill without the need for Project intervention. This is a great asset to have as a company and is exactly what the Project team is looking for in a subcontractor.

I look forward to working with Bowhill again on the next project.



Adam Downie, McConnell Dowell

UNIQUE, SAFE AND EFFICIENT SOLUTION

O'Bahn Tunnel Props & Whalers (Temporary Works)

Client Name: McConnell Dowel

Year Completed: 2016-2017

During this project, there was an opportunity to develop an innovative prop and prop release system to release the force from the temporary horizontal 300mm diameter CHS props once the permanent works were completed and the props were redundant. McConnell Dowel representative Jan Siebel suggested in a passing comment the possibility of using sand as the support and release system as they had used a similar system previously in a different format (vertical support and release of a large load) but they didn't really know how to achieve the different feat at the time. Taking this idea on as a challenge was instinctual for Bowhill Engineering with physical development initiated almost immediately utilising a sliding collar arrangement never before developed. Prototype and testing revealed that there was potential for this system to work successfully in the horizontal plane on a CHS prop.



UNIQUE, SAFE AND EFFICIENT SOLUTION

O'Bahn Tunnel Props & Whalers (Temporary Works)

Client Name: McConnell Dowell

Year Completed: 2016-2017

Engineering calculations and witnessed load testing/measurement completed the process with some slight tweaks and a setting procedure was formulated tested and documented. McConnell Dowell then verified our work through Aztec Analysis and production of the system onto all 50 units was rolled out. This system was seamless and the safety and productivity gains for our client was significant with release of the units being as simple as the removal of a drain bung, once force was released the props sat safely in place until their removal with a crane! The alternative prop release process that was proposed was a clunky method of using a custom hydraulic jack to ease the weight from each prop to enable release, all of this between 5-12m in the air and close to the top of the tunnel's recently installed concrete lid.



AWARD WINNING DELIVERY SOLUTION

Majors Road – Southern Expressway

Client Name: Lend Lease

Year Completed: 2014

Our clients budget for this work was tight which necessitated innovative thinking for us to be able to deliver the quality outcome, within budget. Transport was the key innovation that resulted in a very successful outcome for our client and for Bowhill Engineering.

32.5m long members are not straight forward to deliver to site in Adelaide's South. Our clients budget for this work was tight which necessitated innovative thinking for us to be able to deliver the quality outcome, within budget.



AWARD WINNING DELIVERY SOLUTION

Majors Road – Southern Expressway

Client Name: Lend Lease

Year Completed: 2014



The surety that we realised through the delivery solution was outstanding, our installation process benefited greatly because of the flexibility that we had around crane and weather delays allowing for absolute control of our site resources without costly delay implications

Kevin Shine, Project Engineer, Lend Lease

32.5m long members are not straight forward to transport to any site, let alone Adelaide's South. To minimise traffic disruption and maximise efficiency, the decision was made to move all 8 bridge girders (total of nearly 80t) to the site in one movement. This saw the design of a purpose built transport and storage cradle to ensure a safe and damage free end result. Cradle had to allow the specific truck trailer combination enough room to reverse under the load, this heavy lift deck had the ability to hydraulically raise the trailer deck under the load which allowed the removal of the bolted legs once the load was secured on the trailer with a reverse of this methodology on site for unloading. Engineering calculations and detailed shop drawings were completed to allow for a safe, smooth and problem free execution of the plan.

The custom designed and built transport/storage cradle minimised damage to the coating system in the whole of project handling, zero double handling and maximum cure times were possible due to the methodology, this ensured a successful end result.

The delivery was coordinated so that the whole load was positioned directly adjacent to the permanent bridge site which allowed our client surety to directly unload and install the beams at their absolute convenience and without the need to double handle the heavy, yet delicate items. It proved to be a safe and efficient methodology of both transport and handling on site due to the reduced number of oversize loads on our public roads. There was an added bonus of not having the normal and often difficult coordination of site staff and expensive lifting equipment mobilisation and re-mobilisation for unloading of the items upon their immediate arrival on site on a weekend. This project won an Innovation Award through Lend Lease's National Operations.

NEW LAUNCH METHOD SAVES CLIENT 2 MONTHS

River Murray Ferry Hulls

Client Name: DPTI

Year Completed: 2014-2018

Innovative Methodologies: Soon after award, Bowhill Engineering was able demonstrate proposals and work closely with the DPTI's design team to coordinate many constructability improvements, especially the longitudinal connection of the hull. Using our geographic location to our strength (next to the River Murray) we were able to build the 12m wide, 22m long 70t ferry complete at our manufacture facility (previous builds had been road freighted to Morgan in two halves). The benefits to the client included structural integrity, coating integrity, accuracy, and conveniently allowing DPTI to continue using their Morgan Slipway for some 2 months longer.

Technical Challenges: Large components, transported via river channel to DPTI dockyard. Using a bold approach to this challenge we factored in an allocation for extensive temporary steelwork. We designed this temporary steelwork together with our own engineering and drafting team to be able to launch the completed ferry at the river just metres from our manufacture facility. The coordination between permanent and temporary work packages was the key to the successful launch. The extensive modelling and simulation was done early to bring surety to the process.



NEW LAUNCH METHOD SAVES CLIENT 2 MONTHS

River Murray Ferry Hulls

Client Name: DPTI

Year Completed: 2014-2018



Successful Outcomes: A slick methodology was the key to the success for this project, the large components being built on our site had to be planned and as a result the amount of DPTI's site activities were drastically reduced, a safer and much more convenient outcome for our client DPTI. 4 ferries were built in total over 4 years and 2 separate contracts.

Coating Details: Highly scrutinised 3 coat system internal and external on large modules..



TRIPLING A MINES CAPACITY

Mindarie Mineral Sands Feed Hopper

Client Name: Murray Zircon

Year Completed: 2014

Murray Zircon had an ongoing throughput issue (bottle neck) in their mineral sands mining process. The in-pit feed hopper was not performing, it was inconsistent (constant hang-ups), and was constructed in a way that made clean up and maintenance highly restrictive and simply unsafe. Wayne Oliver the Maintenance Manager at Murray Zircon invited the Bowhill Engineering team to get involved in concept design for a new hopper, however the new hopper was to suit the existing mechanical equipment that was deemed still to be suitable. What followed was a fluent process whereby the engineering, drafting, client input and constructability were able to be considered carefully by way of the Tekla 3D model that was shared around electronically to the whole group via free viewing/visualisation software Bimsight. The newly designed feeder unit seemed to satisfy all client/operator requirements but also allowed efficiency from a manufacture and methodology perspective. Having a well-articulated design with in-built constructability efficiencies allowed Bowhill Engineering to quote with certainty on a known amount of scope with a competitive fixed price lump sum.



TRIPLING A MINES CAPACITY

Mindarie Mineral Sands Feed Hopper

Client Name: Murray Zircon

Year Completed: 2014



We found the Bowhill team so easy to deal with, the process that they coordinated got the best out of everyone and the end result was impressive both in terms of reliable throughput, but also cleaning and maintenance of the unit in service. I would recommend Bowhill, particularly for projects that require innovative solutions

Wayne Oliver Murray Zircon Maintenance Manager

Survey of in-use existing equipment was necessary to ensure that fit up of re-used mechanical equipment was accurately detailed. The concept was based around the actual site requirements and product characteristics, with a high degree of importance placed on safe maintenance and operations personnel access and product capacity and material flow.

Because of the interactive and collaborative approach taken by Boweng and their design team, the engineer, draftsman and the client, a well worked model was produced and thoroughly scrutinised by all stakeholders with a multitude of different perspectives, without onerous design meetings and travel time etc. Murray Zircon stakeholders were ecstatic with the end result as the new feeder unit outperformed the existing unit by more than 100% going from some 150-200t per hour average to a consistent 500t per hour with the new unit and virtually no cleaning inside the unit. Existing Unit was stripped, new unit was delivered, assembled and commissioned within 48 hrs due to careful attention to detail and good fit up of components both new and existing.



PRECISION PAYS OFF

Wayville Train Station 50m long Pedestrian Overpass

Client Name: McConnell Dowell

Year Completed: 2013-2014



Manufacture technique was critical to achieving success on this complex project. The Bowhill Engineering Team were able to be involved right from the start of the design process, allowing us to work closely with the clients design team to coordinate the longitudinal connection points with all disciplines in mind. The important design consideration included structural integrity, aesthetic implications, coating integrity, accuracy, transportability and assembly on site.

With this Complex 3 dimensional shape, irregular bays, and a tight timeline there were many traps, but we used a professional approach to this challenge and factored in an allocation for extensive temporary steelwork into our bid.



PRECISION PAYS OFF

Wayville Train Station 50m long Pedestrian Overpass

Client Name: McConnell Dowell

Year Completed: 2013-2014



With close coordination we designed this temporary steelwork together with our own engineering and drafting professionals to mistake proof our permanent fabricated items. We treated the temp steel like part of the product and gave it the attention that it needed to achieve the precision. This coordination was the key to the successful manufacture and problem free fit up of the modules on site over the operating rail corridor (closed for only 2 hours to install each half).

Accuracy was the key to the success of this project, the very complex project progressed on schedule with the amount of site activities reduced and made safer for all trades due to the sound methodology that was developed at the start of the project.

The highly scrutinised 3 coat system with architectural finish top coat on 13 of large modules required minimal site repairs due to the bolted connection between the modules.



SMOOTH SYNCRONISATION

Gawler Rail Bridge

Client Name: Bardavcol

Year Completed: 2010



Coating details: Painting these large sections was achievable through the use of our blasting and painting facility, 33m long sections completed undercover in a purpose built coating facility. Coating system included a full blast and 3 coats with an automotive grade top coat finish, paint mapping and detailed testing/recording.

Successful outcomes: Very highly scrutinised fabrication, welding and surface treatment procedures all completely satisfying our client and the principle DPTI. Quality plans and ITP were completed with little fuss in a professional and detailed and accurate manner.



HARSH SITE CONDITIONS

Lock & Weir package 2, 4, 5, 6

Client Name: York Civil

Year Completed: 2002-2009

Removable decks units involving complex surface treatment techniques on a submerged fabrication application. High degree of accuracy and finish was necessary. Because of the repetition, highly efficient processes were adopted, such as jiggging, batching. These systems were utilised to produce a fast turnaround and efficiency. Approx 100t of highly complex and extensively scrutinised fabrication and finishing work with associated quality control procedures, documentation and traceability

