

Bowhill Engineering – Capability Statement



Together we Thrive

Contents

- What we do
- A little bit about us
- Capabilities
- Safety
- Compliance
- Company Details
- Capability Statement
- Facilities & Equipment
- Services
- People
- Trade References
- Project History & Referees
- Success
- Low Risk
- Key Differentiators
- Key Projects





We transform communities and our people,
by optimising and building structures that matter together.

What we do

We're specialist fabricators of heavy and complex structural steel. We collaboratively build structures, from design optimisation through to installation, that benefit many Australians.



68 Weber Road, Bowhill SA 5238

BLN: 166373

ABN: 33 911 388 370

bowhillengineering.com.au

T: (08) 8570 4208

F: (08) 8570 4350

E: admin@boweng.com.au

Core Values

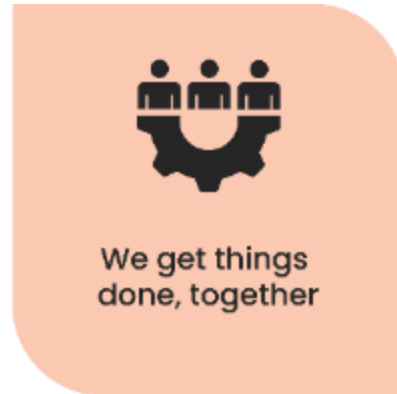

Bowhill Engineering has enjoyed significant growth over the last 5 years and is highly regarded by its customers and stakeholders as a South Australian success story. The company is seen as having a unique position in the market, specialising in large and complex steel structures.

Bowhill Engineering's recent growth has been driven through nurturing collaborative relationships with major construction partners and delivering solid performance on large-scale infrastructure projects (primarily road projects with bridge components).

Customers value the relationship that they have with the Bowhill team, the honesty and transparency, the expertise and (proactive) initiative provided, ensuring cost effective and constructable solutions.

JWPM Consulting – Summary of their External Scan

Core Competencies

In an increasingly competitive and high-stakes infrastructure game, you need a bidding edge. And the bidding edge comes from working with a specialist heavy and complex steel fabrication supplier who will partner with you — not just take your order.



Smarter together

Design optimisation specialists in large, welded components

We start by bringing together the team of experts across design, surveying, drafting, engineering, fabrication, surface treatment, transportation/logistics, and erection to ask the questions others don't and find the efficiencies others can't.



Win before you start

Cost with certainty

When you're looking for specialist heavy and complex steel engineering, most fabricators talk quality; we've got 40 years demonstrating it. Our facilities and equipment are set up to handle the heavy, large and complex parts of any project — think train stations and 50m long road bridge girders.



Complexity done excellently

Systems and process, refinement

We're able to offer certainty of costs because we control our end-to-end process by designing, fabricating, preparing, and painting all our steel under one roof. By being able to take care of the transport through to on-site erection, we're able to control what happens to the whole process.



Committed to our community

Strengthen our region

Helping the community isn't something many structural steel engineers boast about, but as a multigeneration family-owned business, contributing to our community is part of our DNA — and it's what sets us apart.

Capabilities

3,000 m² + 8.1m

workshop floor area & one of SA's widest blast rooms



Heavy and oversize transport specialists with 140t on site movement capability

2500t

Structural Steel Capability per year



AS5131 NSSCS CC3 Certified
IIW MCS ISO 3834.2
TfNSW (RMS) pre-qualified

60+ & \$12m

Staff numbers & project capability



Construction Modelling and detailing

Safety



WHSE Statistics updated monthly – includes LTIFR (Lost Time Injury Frequency Rates)

We work together to ensure we are safe.

We have developed a system that unlocks the combined energy of a highly engaged hazard committee. We remain focused on proactively reducing the risk of injury to all of our staff, and indeed anyone that visits our facility or works with us on our site or our customer's site.

“Working with clients such as McConnell Dowell, OZ Minerals, DIT & TfNSW have seen Bowhill Engineering build QA systems 2nd to none. Clients love our accuracy & timeliness of our documentation and the surety in risk reduction.”

- Jodie Hawkes, Chief Financial Officer

- **ISO 45001:** 2018 Safety Management System
People matter, so we provide a consistent approach to assess and reduce risks
- **Safework SA Awards:** 2012 High Commendation for “Best workplace health and safety management system”
- **National Award:** 2012 “outstanding Site Award”
Australian Steel Institute

Lost Time Injury Frequency				
	One Day 2021	One Day 2022	One Day 2023	Rolling 5 year Average
Fatalities	0	0	0	0
LTI's	23	11	13	14
Medical Treatment	17	12	0	15
Recordable Injuries	29	37	19	18
# Employees	39	52	60	43
# Days	240	240	240	240
# Hours	8	8	8	8
Total Man Hours	74880	99840	115200	81920
LTIFR (Frequency Rate)	30.7	11.0	11.3	16.8
LTIFR Industry Benchmark	35.1	35.1	35.1	35.1
LTI Boweng Target	0.0	0.0	0.0	0.0
Duration Rate	66.8	190.3	0.0	
RIFR (Recordable Injury F	38.7	37.1	16.5	
TRIFR	53.4	23.0	11.3	
IISI	307.2	110.2	112.8	167.8

ESG Framework

Our facility is located on the beautiful Murray River in South Australia. Our passion is to not detract from our environment, we are committed to reducing our impact.

We have committed to our SET and use our ESG (Environmental Social Governance Framework) to monitor our progress.

We also have a [Community Energy portal](#) which we share renewable energy with our community. Click the link to learn more and consider joining our Grid.



COMMITTEE MEETING

Projects Completed – Last 12 Months

Project	Status	Completion
BFC Business Training	Completed	October 2022
SEC Committee Meeting x2	Completed	April, August 2023
Battery Feasibility	Completed	August 2023

Projects in Progress

Power Factor Correction	In Progress
Final Battery Plan and Installation	In Progress

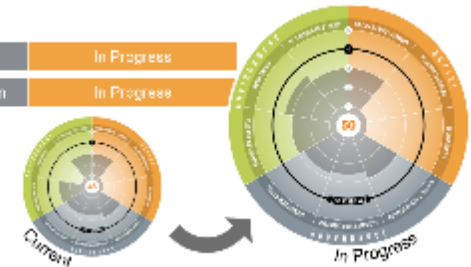

Commitment to SUSTAINABLE ENERGY TRANSITION

Bowhill Engineering and Midstream Energy have undertaken a collaborative, science-based factual process to develop a comprehensive sustainable energy transition (SET) road map.

The SET road map is underpinned by a detailed baseline assessment of Bowhill Engineering's assets, projects and energy usage and has identified a broad range of opportunities for future energy efficiency, operational and other low-carbon renewable energy.

Bowhill Engineering have committed to implementation of the SET road map which will build energy management resilience and deliver the following sustainability outcomes by 2028:

- 10% reduction in total power use
- 100% renewable sourced power by July 2022, including:
 - 50% of self-generated power
 - 50% of Community Energy sourced power
- Community Leadership through driving a local Community Energy Program
- 10% Renewable Energy for non-core facilities and other scope 2 emissions by 2028

Midstream Energy will support Bowhill Engineering by facilitating governance and stewardship of the SET road map implementation through project management, delivery, key performance indicators, monitoring and reporting, and financial support and to ensure the realisation of the proposed programs.





Compliance

**We do things the right way, every time.
No exceptions.**

We're immensely proud of the fact we've embedded compliance into our culture. This dedication to doing things the right way for our staff, our clients, and our environment is how we're able to point to a track record in quality, safety, and environment that's unmatched in our industry.

“Bowhill Engineering's commitment to its Integrated Business Management Systems including Safety is by far the best that I have seen in a small/medium manufacturing business. Its commitment to process compliance via a sophisticated document management system that is easily accessible to all stakeholders is commendable.”

- Darren Lea, Director, Perpetual Results Australia

- **ISO9001:** 2015 Quality Management System
Provides certainty and reduces risk, ensuring a professional system for every process
- **ISO45001:** 2018 Safety Management System
People matter, so we provide a consistent approach to assess and reduce risks
- **ISO14001:** 2015 Environment Management System
We care about where we live and want to ensure our environmental footprint is minimal
- **AS5131:** 2015 Steelwork Compliance Australia (SCA) – Construction Category 3
Industry regulated to ensure quality compliance of structural steel fabrication and erection
- **AS3834.2** Weld Australia – Cert No. AU 087 Rev 0
- **TfNSW National Prequalification** – Dec 2021
- Building Work Contractor
Licence registration details for construction and building works



Company Details

Trading Name:

Bowhill Engineering

Registered Address: (and principal place of business)

68 Weber Road
Bowhill SA 5238

Bowhill Engineering Pty Ltd ITF Hawkes Family Trust

Registered: 2/5/1995

Licensing and Business Registration:

ACN: 069 189 519
ABN: 33 911 388 370
Contractor Licence #: BLD 166373

Workcover:

Policy Number: E13282201

Public Liability Insurance:

Company: Elders/Lloyds of London
Policy Number: GLQ 15 0000384
Amount Insured: \$20,000,000

Bank Details:

Bank:	Commonwealth
Branch:	Murray Bridge
BSB:	065-505
Account No:	1003 3714
Account Name:	Bowhill Engineering P/L

“Bowhill Engineering has always demonstrated outstanding communication whether it be complying with contractual obligations or conveying engineering solutions to enhance the overall project directives and timelines. Respect for our clients views and requirements have always been met with positive enthusiasm even when dealing with difficult or demanding circumstances. Their QA and safety systems are very mature and it is clearly evident that they take seriously their commitment to safety and quality, in both action and documented processes...”

- Mark Osborne, Business SA Advisor



Capability Statement

Bowhill Engineering is an innovative structural steel engineering firm with specialist capability in large complex steel structures. Founded in the early 70's, for the past 50+ years Bowhill has developed an enviable track-record for project delivery. Bowhill's reputation is built on:

- Specialising in large complex structural steel
- Being easy to do business with
- Offering a collaborative problem solving approach
- High capability for developing innovative solutions
- Track record for delivery-on time and with high quality
- Price competitiveness

Bowhill is widely recognised for excelling at technical challenges. Their collaborative approach draws together project stakeholders driving down the risk profile to ensure successful outcomes. Their geographic location suits their core competency and allows efficient transport anywhere in Australia.

Bowhill directly employs a stable workforce of 60+ highly specialised staff, this strengthens their community and provides the ability to deliver world class innovative solutions for their national clients. The firm delivers some \$15 million worth of landmark projects annually.

Bowhill lead the way with their integrated systems and professionalism, a "boutique" firm focused on a specialisation in a very specific niche in the construction market.

Regarded as specialists in complex & heavy structural steel

fabrication, particularly larger components. Bowhill have deliberately developed their core competency which has allowed them to highly progress their skills. When coupled with their purpose built fabrication facility complete with one of Australia's widest blast chambers, their competency is highly sought after. This allows Bowhill to produce these challenging size projects with absolute safety and the efficiency gained translates into competitive rates.

Bowhill's target markets include government infrastructure, mining, marine and, defence - Bowhill Engineering have successfully completed many critically important projects for these industries.



Quality Policy Statement

Bowhill Engineering is committed to quality providing our clients a Lean Business System that is an Integrated Management System that complies with ISO 9001:2015

Our quality objective is to meet or exceed all customer & applicable legislative requirements and expectations in a proactive, professional and cost-effective manner.

To achieve this objective, we will:

- Set objectives and targets to measure our performance and identify opportunities for improvement.
- Provide adequate resources to continually review and improve our business process and quality management system
- Encourage all people to integrate quality management into the way we work and promote its application as a method for continual improvement within their area of responsibility.
- Actively seek performance feedback from our customers and address opportunities for improvement that are identified.
- Ensure that we communicate our commitment to quality to our staff using a variety of methods.
- This policy and associated documents shall be subject to continuous review.

This policy applies to 68 Weber Road, Bowhill SA 5238 and includes all business activities, operational activities and administration services associated with heavy and complex structural engineering, located at this site. This policy is to be read in conjunction with our [Integrated Systems Management Manual](#). It applies to all staff, clients, customers, suppliers and sub-contractors whilst they are located on our site. The IMS Manual is the over-riding top document.

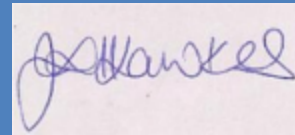

Jodie Hawkes
Chief Executive Officer

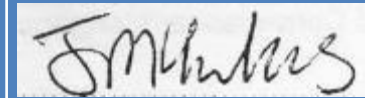

Jeremy Hawkes
Director of Business Development



bowhill
engineering

Together we Thrive

Facilities & Equipment

- 2,500 m² — Main Workshop Assembly 25m span open layout for larger components
 - 2 x 20t Overhead gantries
- 1,000 m² --- Assembly Workshop
- 1500m² - B5 High lift Workshop – 23m high (*expected completion date mid 2024*)
 - 1x 100t (16m hook height) & 2 x 32t (12m hook height) Overhead Bridge Cranes (20m span)
- 20,000 m² of Onsite Storage with 5+ acres of hard stand area (6.7 hectares – total land package)
- Onsite lifting equipment:
 - 1x 33t capacity forklift, 1x 16t, 2x 12t capacity forklifts, 1x 8t, 2x 4.5t and 4x 2.5t
 - 2 of 70t heavy duty engineered jinker units complete with hydraulic lifters on each unit
 - Movement of up to 140t items on site can be achieved easily and storage onto our large range of rated trestles for easy loading onto road transport.
- Heavy Lift Truck Trailer combination:
 - Subcontractor; intra and interstate movement of up to 65m long, 150t, 5m wide 6+m height segments
- Welding equipment (Mig Welders):
 - Lincoln, Essab, WIA, CIG Mig welders, all approx. 400-500a with remote wire feeders
 - 2x sub arc welders 1000 Amp (Lincoln, Esab) 7m high SAW Boom
 - 2x Stud Welders (Soyer – up to 22mm diameter studs)
- 1000m² Surface Treatment Facility:
 - Surface treatment undercover area is insulated and climate controlled
 - Blast chamber 8.1m wide – widest in SA (capable of coating 70m long items undercover)
 - 4 blast nozzles at once via a 6t Mega Blast Pot
 - EPA approved
- 400t+ of Temporary steelwork for modification and hire:
 - Large road frames and crane mats
 - Bridge support towers (for use with SPMT's)
 - Spreader beams, headstocks, props
 - Formwork, sand jacks, temporary bearings, packers etc

Uniquely valuable services

Bowhill Engineering have a proven track record, the many benefits to our clients are enforced by the rock solid reputation that we've built over some 40+ years in business.

Methodology Development

Our wealth of experience, innovative staff and state of the art software, well equips us to serve our customers with safe, efficient and synchronized methodologies. ECI type contracts or complex tasks that need "proving" before manufacture are common for Bowhill Engineering. 3D simulation enables us to electronically trial proposals, identifying the merit from a physical, safety and practical, standpoint.

A strong methodology development capability allows us to maximise build-ability and accuracy.

Speed and Accuracy

Drafting using Tekla 3D software and the associated free Trimble Connect collaboration software has allowed us to achieve lean manufacture principles and error proofing through all project stages. This results in NC format files (which are developed straight from the project model) being sent via email straight to the steel merchant for CNC processing. Accuracy and speed are huge advantages resulting from this process.

Metrology

Bowhill have recently developed in-house technology to accurately measure larger items in 3D using our Trimble X12laser scanning tool. This is a survey grade machine that can also provide laser scanning to ensure accuracy via electronic comparison to the 3D model.

“

We do things for our customer's convenience, not our own”

- Jeremy Hawkes, Director of Business Development



Services (cont.)

Value for money

With a committed stable and experienced workforce (average staff retention rate in excess of 5 years), with a great workplace culture, productive behaviours, we are able to reliably produce structural fabrication components of exceptional quality at competitive market rates. We do this through our lean manufacturing processes as well as utilising SA's extensive industry supply chain. We manage the potential risks of outsourcing by fostering strong supplier networks and contracts.

This approach is an extremely effective way of achieving an impressive result for all stake holders on a project. Minimization of capital outlay reduces costly overheads, increases our overall capacity and benefits our clients through the resulting low cost structure. This strategic approach allows an impressive quantity of available capability, whilst allowing a nimble structure with diverse skills. This ability to be very flexible and adaptable can be applied to many different challenges and industries without compromising our core focus of heavy and complex structural steel.

Reputation

We have runs on the board. By nominating us on your project team, your clients or stakeholders will be favourable to your overall proposal.

Bowhill Engineering have been active in the building and construction industry since the late 1990's. Our reputation is something that we are passionate about and something that we take great care of. As you well know, in this industry any

mistakes are well known and reputations are easily damaged. Throughout this entire time Bowhill Engineering have not one tarnish on their reputation, quite a testament, and rarely seen.

Surface Treatment

A modern surface treatment facility that is specifically designed to efficiently handle large components, in an environmentally sensitive way. Our Blast room is one of the widest in Australia! The ability to complete this critically important process on our manufacturing site is hugely beneficial to you as our client because it results in savings, quality control and effective loading on transport. In simple terms we can ensure that you get what you want, when you want it! Without this in-house service other fabricators are at the mercy of the industry, and they simply do not have the control that this critical process demands.

“The coating process protects the clients valuable investment, it must be right”

- Tom Dennis, General Manager



Early Contractor Involvement (ECI)

Why assembling the right construction team early creates winning outcomes

Our experience tells us that there are fantastic, mutually rewarding and industry building solutions waiting to be discovered.

It just requires the right approach to unlock them.

We all want a competitive advantage, we all want to lower risk and increase performance and profit, could this ECI approach be the most effective way to do all of this, for all parties?

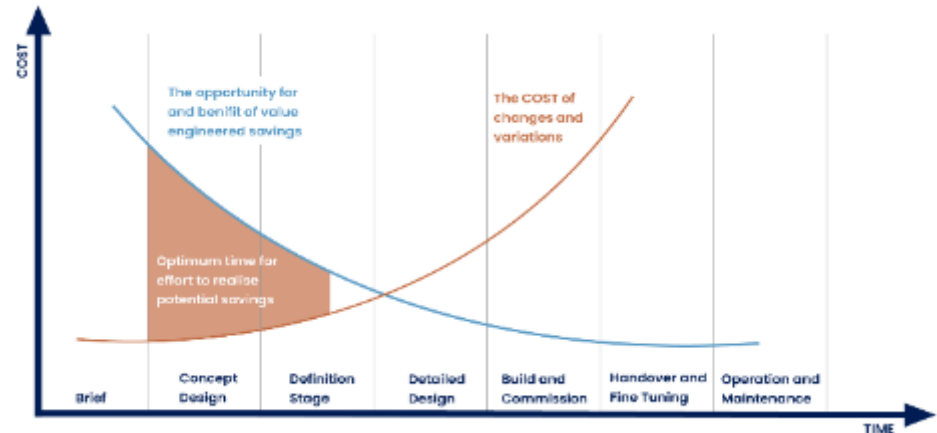

There are many positive outcomes that we have seen as a result of our involvement in this approach and they are experienced by everyone involved, not just from our perspective as a subcontractor.

The next-level understanding of critical trade nuances is normally out of reach of designers and contractors because trades keep their secrets as their own IP. Sharing of knowledge helps to drive down risk, drive up smart, thoughtful and efficient design and encompass the overlapping and inter-dependent trades.

Building relationships with the best subbies in the industry is a smart approach, it helps your organisation and limits your competitors access to them. Learning together and creating an inter-dependent culture where "none of us are as smart as all of us" make a strong team approach. Very hard to keep success away from a strong team! Wining, but not at someone else's expense! Winning together!

Magic can happen, industry norms can be surpassed with better more unified design that supports the whole supply chain and program.

- With the right people (experienced in diverse but complimentary ways),
- Working together to an aligned goal, where all parties can benefit from smarter solutions
- Freedom for brainstorming and challenging the status quo and inter-dependent exchange of ideas

Contacts



Jeremy Hawkes
Director Of Business
Development
jeremy@boweng.com.au
0417 868 356



Jodie Hawkes
Chief Executive Officer
jodie@boweng.com.au
0438 704 229



Tom Dennis
General Manager
tom@boweng.com.au
0403 567 641



Samantha Krollig
HR Manager
sam@boweng.com.au



David Holland
Project Manager
david@boweng.com.au
0439 310 637



Ben Quinn
Quality Manger
ben@boweng.com.au



Kristian Livolsi
Advisory Council (Chair)
kristian@kristianlivolsi.com.au



Jason Clark
Advisory Council
jason.clark@symonsclark.com.au



David O'Sullivan
Advisory Council
David.osullivan@ecospecaus.com.au



Darryl Webb
Advisory Council
drwebb@lm.net.au

Contacts



Rod Koza
Accounts Coordinator
accounts@boweng.com.au



Michael O'Malley
Quality Supervisor
michael@boweng.com.au



Peter McIntyre
Project Manager
peter@boweng.com.au



Jarrad Woodward
Production Supervisor
jarrad@boweng.com.au



Declan Fritchley
Apprentice
Team Representative



Chloe Anderson
HR Coordinator
chloe@boweng.com.au



Cheyenne Gladigau
WHSE Assistant
cheyenne@boweng.com.au



Reece Cockshell
Project Coordinator
reece@boweng.com.au



Tyler Hansen
Workshop Team Leader



Leigh Tobin
STF Team Leader



Courtney Brown
HR Assistant
courtney@boweng.com.au



Demi Herrmann
Project Administration
demi@boweng.com.au



Andrew Holland
Project Assistant
andrew@boweng.com.au



Tom Philp
Apprentice Team
Representative



Ethan Klemm
Project Draftsman
Draft & Technology
ethan@boweng.com.au



Sharnii Ackland
Trainee Administration
Assistant
sharnii@boweng.com.au



Chelsea Haby
Project Administration
chelsea@boweng.com.au

Trade References

Employee Information:

Current Employees: 60+

Trade References:

- Adelaide Profile: 8384 6449 - aazolins@adelaideprofile.com.au
- Brice Metals: 8405 7111 - BenB@brice.com.au
- Konnect Fasteners: 8300 8700 - Daniel.Herbert@konnectshop.com
- Korvest: 8360 4548 - George.Elvin@korvest.com.au
- United Fasteners: 8360 4622 - andrew.norbury@unitedfasteners.com.au
- Ferrocut 8130 0600 - srowle@ferrocut.com.au



Project History - Referees



Project Name	When	Project	Referee
Sydney Gateway SB91 & SB61	2022-23	SB91 – 1x girder, 75m long, 100t, SB61 – 5x girders, 75m long, 671t (RMS TfNSW)	John Holland Seymour White Ray Chow 0400 956 330
Prominent Hill – Head Frame	2022-23	2.5m diam columns, 60m high, trial assembly of 300t with a total of 650t	OZ Minerals (now BHP) Charlie Fearon 0437 215 459
Ovingham	2021-22	16 Bridge Girders – 1400t, Temporary Works (CC3)	McConnell Dowell Glynn Thomas 0455 319 185
Granite Island Bridge Temporary Works	2021	400t of temporary steel supplied	McConnell Dowell Jan Sibert 0416 876 565
Coopers Creek Bridge	2021	1x span, 30m long weighing 32t over the Coopers Creek	Bridge & Marine Wayne Smith 0429 363 745
Regency to Pym	2020-21	20 Bridge Girders – 1500t Pym Street Pedestrian Bridge – 64m long – 110t (CC3)	McConnell Dowell Nigel Hird 0417 167 425
Gawler River Rail Bridge	2020-21	2x Through girders 28m long, 19x cross beams, 18x bracing tubes	Bardavcol Adam Yates 0438870341
Flinders Link	2019-20	20 Bridge Girders – 1500t Temporary Works (CC3)	Gateway South Jordan Bloxham 0477 356834
Snowy 2.0 Bridges	2019	Yarangabilly & Wallace Road Bridges (CC3)	LEED Shane Burke – 0400 166 440
Williams St Bridge	2019	2 x Through Bridge girders, 2 header beams & 36 cross beams (CC3) - 350t	Rail Infrastructure Alliance Anthony Baldi 0455 783 143
Oaklands Crossing	2018-19	Pedestrian Bridge & Canopy - 190t	PTPA Adam Downie 0427 716 554
Darlington Upgrade	2017-18	2x 180 dual lane road bridges – 1100t Extensive temporary works	Laing O'Rourke Nigel Hird 0417 167 425
Southern Expressway Duplication	2012-14	3x road bridges, 5x pedestrian bridges, sign gantries	Lendlease Kevin Shine 0418 932 517
Wayville Train Station Pedestrian Bridge	2013-14	50m long geometrical pedestrian bridge & lift tower	McConnell Dowell Nigel Schmidt 0419 037 551

Success



2019 Telstra Business Awards Finalist
South Australia
Medium and Making Waves

T BUSINESS AWARDS

#TelstraBizAwards

SL 2015 TRAINING AWARDS

WINNER
SMALL EMPLOYER OF THE YEAR

AUSTRALIAN TRAINING AWARDS 2015

FINALIST
SMALL EMPLOYER OF THE YEAR AWARD
www.australiantrainingawards.gov.au

HALL of FAME
2019 Inductee

F B A
Family Business Awards

2015 South Australian Regional Awards

WINNER Large Business

World Australia
WINNER
Company of the Year

AUSTRALIAN LEADING CIVIL CONSTRUCTION MARKET
EARTHMOVER & CIVIL CONTRACTOR
AWARDS 2015

Key Differentiators

Our ECI program will help you win before you start! We are so confident in your satisfaction that we'll refund the entire cost if it doesn't!

Bowhill Engineering have developed years of experience with regards to ECI (Early Contractor Involvement), we have the runs on the board, case studies and testimonials to clearly demonstrate how powerful the process can be. We encourage your team to check in with our referees (provided later in this document) to support our claims. If your team are looking for a specialised contractor that they can establish a ***mutually beneficial sustainable partnership with a trust based and collaborative relationship*** then it'd be hard to go past Bowhill's alignment to this mission!



Key Differentiators

Bowhill Engineering are a wholesome, financially solid, high performing and innovative regional 2nd generation family business, we've been around for 50+ years.

We enjoy an exceptional reputation in not only our industry, but our region and our community.

We currently employ 15 apprentices and 2 trainees, we invest in our people's future and pride ourselves on building regional leaders (1.8% of Bowhill's turnover is invested in training our awesome staff)

Our NPS (net promoter score) is world class (currently at 100) as rated by our clients. This is an excellent indicator of what you can expect of our service offering.



Key Project Success Factors

Bowhill have a good understanding of this project's criticality, our particular focus is on how we can demonstrate the following key areas.



- Capacity
- Flexibility
- Complimentary contractor networks
- Metrology/accuracy
- Off site movement and handling
- Off site storage
- Road transportation
- Heavy Plate fabrication
- Welding to high specification
- Post weld machining of heavy items
- Blast & coating of larger elements



Key Project Success Factors

Capacity to complete this project will be coming available in March 2023. Projects that fall into this program window would have our full focus and attention.

Flexibility is Bowhill's strength, we have a reputation for working in with clients, even when things don't go exactly to plan. This of course goes both ways, but for example, we often see timing of design or approvals influencing program alterations. Through collaborative approaches we've managed to discover creative ways that can minimise the impact both from a timing perspective, but also commercially. This brings our clients piece of mind that flexibility is possible when unforeseen issues become reality.



Key Project Success Factors

Network of complimentary contractors, Bowhill have already aligned with some of the best contractors in the industry to supplement our own internal capabilities. These specialist trades when handpicked form a team with collaboration, depth and experience, it ensures certainty of outcome.

Metrology, using our total station surveying tool (that can also conduct laser scanning), given the criticality, we'll be able to complete a series of measurements that can provide absolute dimensional control over the whole process from start to the final post-fab alignment to the specified tolerance via the as-built check. Measurements are compared via a heatmap and measurement matrix from point cloud to the 3D Tekla BIM model. Freely shared amongst the construction team as required, it will bring confidence for the installation process. In simple terms, things will fit without disruptive interference or inefficiencies.



Key Project Success Factors

Transportation and handling of larger elements is par for the course at Bowhill Engineering. We have developed safe and efficient processes to construct and move larger elements around at our well equipped site. Significant investment has been made in our jinker trailer and trestle system to seamlessly move up to 140t segments using our own staff and equipment. This process can also be adapted to work with great effect at your site using SPMT modules if deemed appropriate.

Free off site storage at Bowhill's facility is not a problem in the event that completed elements need to be staged prior to site install.

Road Transportation of the finished elements is an area that is well catered for at Bowhill Engineering. Specialised solutions utilising temporary steel or custom designed and engineered bolsters are options for the safe movement of the transfer beams. Heavy vehicle route from Bowhill to almost anywhere in Australia has proven to be successful and we would expect no issues when the time comes for delivery.



Key Project Success Factors

Heavy Plate Fabrication is what we do, it's Bowhill's speciality, we have been working with high spec, thicker plate projects exclusively for many years. Weld procedures, stress relief, heat distortion control, material testing and grade selection, NDT frequency as well as choosing the most effective type of testing are common considerations for Bowhill's team. We have a many examples of similar projects, this work is not new for us, we have demonstratable experience to complete this work with confidence.

Welding aligned to high specification requirements has become a smooth process within our QA, project and production teams. We run a process that we call "technical review" so that we as a team clearly understand the requirements within the engineering specification and to ensure that we provide complete compliance to that requirement. Even before we submit a tender response we have a detailed understanding of what's required, this avoids any gaps between what's been allowed and what our clients expect.



Key Project Success Factors



Mt Derrimut Road Project WPA – Location-Melbourne

Bowhill Fab/weld (Jan-Feb 2023)

Scale- 90t 100mm flange thickness, 3m x 32mm thick web , 45m long

Key Project Success Factors

Post weld machining of heavy items but done utilising the metrology data to allow true alignment of the physical and virtual 3D model.

The next few slides demonstrates how Bowhill plan to manage post weld machining combined with our in house metrology (Trimble X12 Total Station) through a case study from our most recent project at Oz Minerals Prominent Hill South Australia.

Bowhill have also forged a strong partnership with TransAlign, who are specialists in machining off site using specialised mobile machining equipment. <https://www.transalignism.com.au/> Depending on the item, we have experience in using effective approaches such as detailing and ordering and fabricating plates oversize with an appropriate amount of "green" on the critical contact points for efficient in-situ machining to tolerance once manufactured.



Key Project Success Factors

Blasting and coating of larger elements is also what we do, we've been completing this scope for as long as we've been in the game. Over the more recent years we've upgraded our facility to handle longer, heavier elements in a similar way to that of a ship yard. We've got an impressive facility that utilises 4 blast operators/hoses at once, this gives us the ability to completely blast large (up to 110t) elements and prime coat within less than a 10 hour period. Because we do this in house at the same facility we enjoy the efficiency of an integrated workflow and quality piece of mind.



SURFACE TREATMENT
FACILITY, 70M LONG

OZ Minerals - Headframe Case Study 2022



- 67M TALL
- 53M LEGS
 - 4 PARTS – 30T EACH
 - 2.4M DIAMETER PIPE
- 1.6KM CABLE LENGTH
- 2X 30T ORE BUCKETS
 - 60KMPH
- 400T UPPER ASSEMBLY



A-frame trial assembly

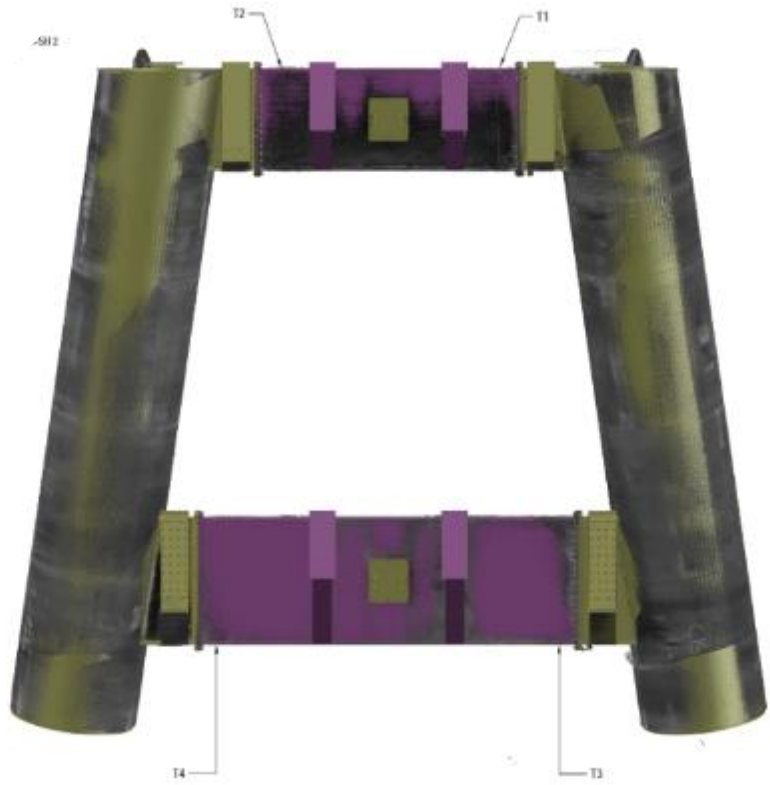



Completed upper legs



Completed Head Frame
Structure

Key learnings

Heat distortion

- Because of the large plate size for box beams / Can connections, heat distortion couldn't be fully controlled.
- Machining was needed to return distortion to a full contact flat face.
- Machinists needed clear and accurate data to complete their scope accurately.
- In-Situ machining has not been regularly done at Bowhill Engineering prior.

Digital data collection

- Due to the large quantity of connections, traditional measurement processes were not satisfactory.
- Point cloud data was not applicable for data interrogation.
- New technology was implemented from various recommendations.
 - Point cloud data
 - Total station measurement
 - Flatness survey





Back to back assembly - distortion control

Despite distortion control, 50 plate full penetration welding from webs/flanges to connection plate still pulled face out of tolerance

		C18 - B10											
		SURVEY FROM MACHINED SURFACE											
		MAX	-										0.28 mm
		MIN	-										-5.06 mm
		Standard deviation	-										1.81 mm
		EDGE B											
o	X	315	430	645	860	1075	1290	1505	1720	1935	2150		
Y													
	164	-1.24	-3.30	-1.05	-2.81	-2.93	-3.43	-1.61	-3.76	-2.11	-0.35	-2.81	
	329	2.82	0.57	0.08	0.28	0.09	0.03	0.00	0.25	-0.17	-0.13	-3.94	
	493	3.61	0.44								0.00	4.59	
	657	-1.94	-0.52								-0.07	-5.06	
EDGE C	821	3.94	0.46								0.07	4.66	
	986	3.04	0.42								-0.11	-4.00	
	1150	2.07	0.70	0.57	0.25	0.47	0.31	0.01	0.03	0.05	0.00	3.24	
		-1.35	-1.70	-1.46	-3.52	-4.15	-4.15	-3.80	-2.64	-0.69	0.15	-1.10	
		EDGE D											
		ESTIMATED THICKNESS TO REMOVE TO ACHIEVE FULL FLATNESS											
		-5.06 mm											





Using specialised contractor TransAlign to clean up faces via a custom fabricated machining frame



Using total station measurements to ensure that the post weld machining of the faces was true to the 3d model geometry rather than just cleaning up for a flat surface, with the potential for connector plates to be out of the correct plane.

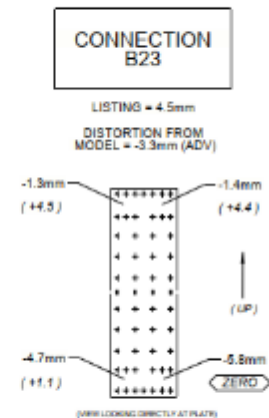
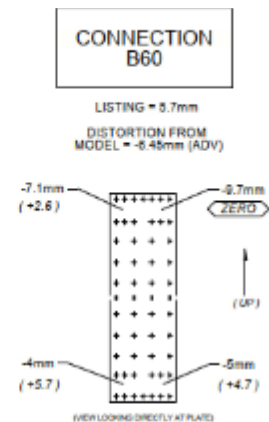
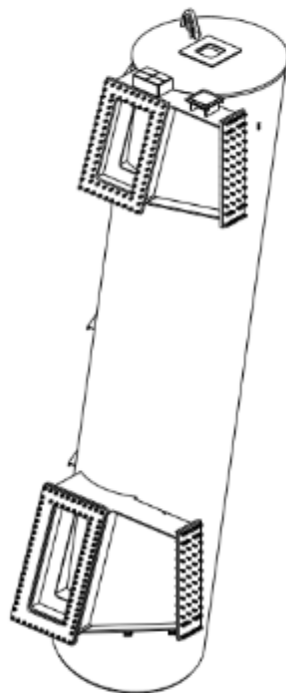
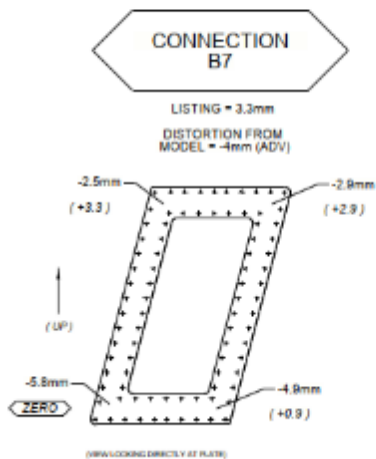
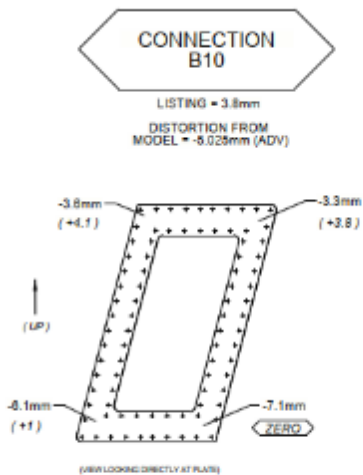

Drawing Notes		Client	
DATA IS TAKEN FROM TOTALSTATION SCAN ALIGNED FOR BEST FIT COMPARED TO MODEL		Project: 106 - Project Name	
		Drawing Title	
Rev. Date Description		Drawing Number: C18 SURVEY	
		Version No: 5	Modelled by: Modelled by
		Scale: 1:30 1:35 ****	Issue Date: 24.08.2012



Insitu machining at Bowhill's facility



Insitu machining at Bowhill's facility, custom fabricated support framing to suite application.

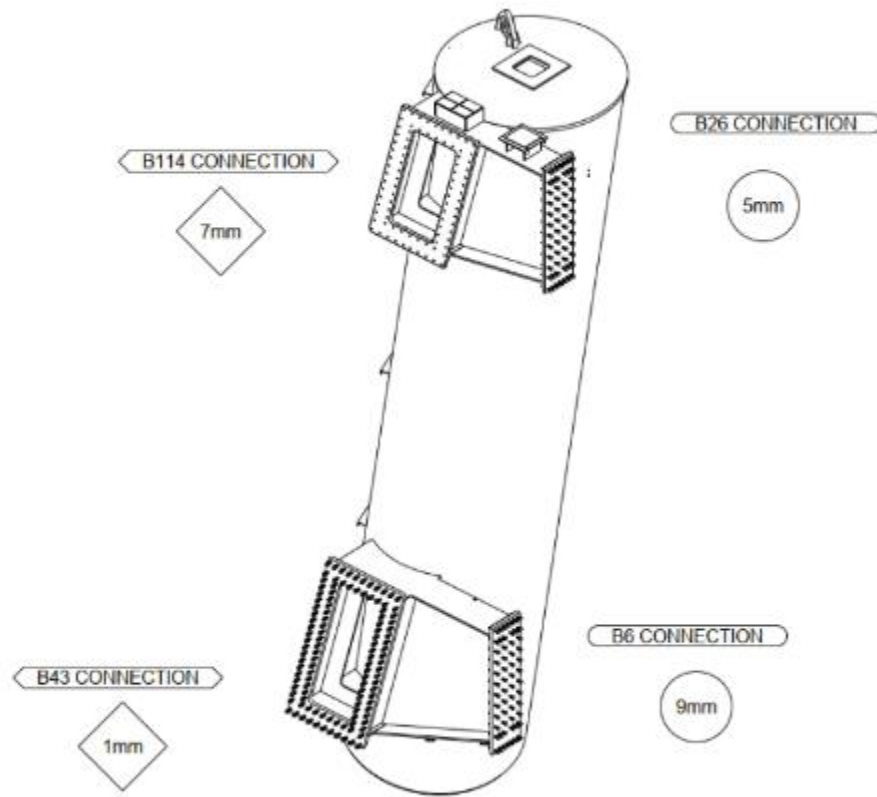

Packer thickness drawing after machining has been completed.

Bowhill's new in-house technology



SX-12

ROBOTIC TOTALSTATION

The SX12 is a robotic total station with scanning capabilities, meaning we can use it to achieve high accuracy measurements as a total station, but also use it as a point cloud if required for a project. This model gives additional functionality to the user,

SX-12 features



Autonomous
design



Total - station
survey

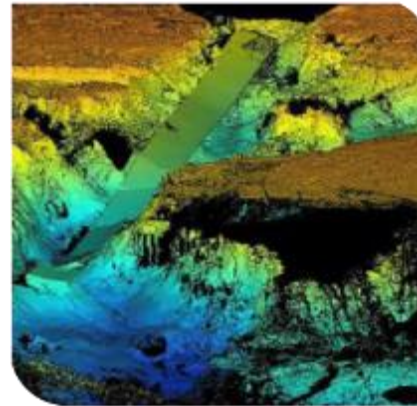

Point cloud
scan



Post - scan
measurement

Low Risk

Risk minimization is paramount to us. We ensure that our systems and procedures are sound and robust. Being accredited for Quality, Safety & Environment as well as Pre-Qualification for industry groups such as NSSCS to an impressive CC3 level, ensures we maintain the high standards that you expect and that we have set for ourselves. Continuous Improvement utilising project debriefs and being dedicated to then developing the most efficient preventative systems allow us to move the wheel of progress without slipping backwards.

We have a dedicated management representative working to ensure all Policies & Procedures reflecting current work practices. We are extremely proud of the way we “choc the

wheel” which ensures that our Risk Management Policy is relevant & impactful.

“ We have a passion for what we do, the prospect of building something like a complex pedestrian bridge gets us very excited ”

- Jeremy Hawkes, Director of Business Development



Early Optimisation

Regency to Pym

Client Name: McConnell Dowell

Year Completed: 2020

Early design optimisation; helped set this project off in the right direction. The macro level trade considerations such as mill plate sheet size availability, cross section and girder length/weight limitations, weld joint design and the like were considered as early as the main contractor tender stage. Bowhill were happy to provide this early input with no obligation and extend this service to other contractors who would like macro level trade focused feedback on concept designs.

Design coordination meetings; held (mostly via video conf) at regular intervals with the whole engineering and construction team helped to avoid a lot of time consuming RFI 's and clarifications during the engineering drawings development and shop drawing/modelling stage.

Project Modelling; The collaborative nature of Bowhill's modelling process is building towards having just one coordinated shop drawing and engineering model rather than separate engineering and shop detailing processes. This we believe to be a huge opportunity to further progress towards true BIM practices and to build the coordinated process that captures many win-win outcomes for all stakeholders. It can't be understated the learning process that happens as a spinoff benefit from these collaborative discussions. The learning transfer happens across the full spectrum of stakeholders it is not one way from learned to practical as you might expect, rather even senior engineering and construction staff can gain practical insights from trade focused collaborators & visa-versa.



R2P (cont.)

Temp Works; The use of temp works on this project has been significant mainly due to the installation methodology where the majority of the bridge is pre-built, finished from insitu slab, road surface, barriers etc right up to light pole bases and then installed using an SPMT (similar to the Darlington road bridges a few years ago). In this instance, the prebuild happens some 500m from the permanent location and occurs as 2 x 1300t 84m long x 15m wide sections of bridge supported at permanent height of around 6m to underside of girders. A significant scope and with the innovative reuse of 200t of previously used steel that Bowhill have secured from previous works (+100t of new steel), we've done this work at lower cost than new steel only (\$1m for all new verses \$500k mix of new and repurposed).



Implemented Learnings

Flinders Link Railway Bridge & Temporary Steelwork

Client Name: Gateway South (Fulton Hogan)

Year Completed: 2018-2019

20 Open top box girders for the Railway Bridge simply supported girder segments

Implementing learnings;

Being the 4th steel bridge at this project site, the efficient design features that had been uncovered on previous scope packages were fed into the design development for this bridge.

This assisted with speeding up the design process and allowing cost savings to be realised by the Gateway JV during the tender period.

Bowhill were active in sharing and assisting in this process and full credit to the Gateway team for pursuing this continuous learning discipline.

We believe that these initiatives are helping to strengthen the case for building steel bridges in favour of other competing materials.



Sand Jacks

Sand Jacks; Engineers specifications increasingly state that Bridge girders are not to be installed directly onto the permanent bearings. This lends itself to an opportunity for an innovative solution.

Bowhill have been providing their inhouse IP for this solution via their modular sand jacks. These jacks can be pre-set at the required height and can accommodate the unforeseen loads during the construction process. Then once all works completed, they can be safely lowered in a controlled manner without the use of any complicated or expensive mechanical, electrical, or hydraulic assistance.

It's as simple as either blowing out the sand with compressed air or some site teams have even used a vac-truck to remove the sand and avoid any need for clean-up. We now have a range of these jack kits in stock ready for incorporation into our next project.



Offsite Pre-Assembly

Williams Street Bridge, South Yarra

Client Name: Railway Alliance Australia

Year Completed: 2019

Railway Corridor Challenges: Right from the start this project had some ambitious goals, being a bridge within the rail corridor in Melbourne. The window for closures to install were small and difficult to change.

This being the case the Metro Tunnel/RIA team needed the surety that everything would fit 1st time to allow the erection of the whole bridge and trans-floor slabs to happen in just one weekend.

This coupled with a very tight construction timeline leading up to the install generated a massive challenge for Bowhill and indeed RIA.

Add to this situation the requirement to pre-assemble the main elements off site (at Bowhill) to guarantee fit-up on site and the stage was set for one heck of a project.



Offsite Pre-Assembly (cont...)

Bowhill's team worked big hours and adopted some innovative procedures to bring the fabrication and welding into line with the program. Next challenge was taking the main elements (some only partially completed) out of the workshop to allow the full-scale trial assembly without "burning" too much program.

Fortunately, Bowhill had only just finished the civil works for their 110m x 110m hardstand extension which was available in perfect time for this significant prebuild of the 60m x 25m x 4m deep main girders.

Bowhill's CC3 compliance (NSSCS) was another big tick to the RIA project team, it also provided them the piece of mind that the systems and procedures required for bridge building were thorough and complete and would not hinder the project.

Safety/efficiency; To safely use the onsite crane's maximum allowable rating Bowhill provided the data from an in-house developed calibrated weighing system. This data extended to all larger elements and was done after surface treatment to ensure absolute data integrity and lift planning surety. We offer this service to all of our clients as a value add now.

Timing; It is testament to the whole team that the entire structure was able to be safely erected over the rail corridor within RIA's ambitious program of just one weekend.



Saved \$350k and 4 weeks on Critical Path

Darlington Bridge 3, 14 & Temporary Steelwork

Client Name: Gateway South (Fulton Hogan)

Year Completed: 2017-2018

During the main contractor tender phase Bowhill Engineering helped our client Gateway South (Fulton Hogan/Lang O'Rourke JV) flesh out some critical constructability feasibility checks. This process was done well before award of the contract to Gateway and hence well before any contract being negotiated with Bowhill Engineering. This process uncovered some important budgeting information to allow our client certainty with their bid to the project client (DPTI). Early Engagement is something that Bowhill Engineering invite on important projects where there are genuine opportunities to find better ways to improve the scope. This service is offered without any expectation, a reliance only on openness, innovativeness, honesty and helpfulness shines through and this alone often sees us being chosen to represent our trade during the actual project.

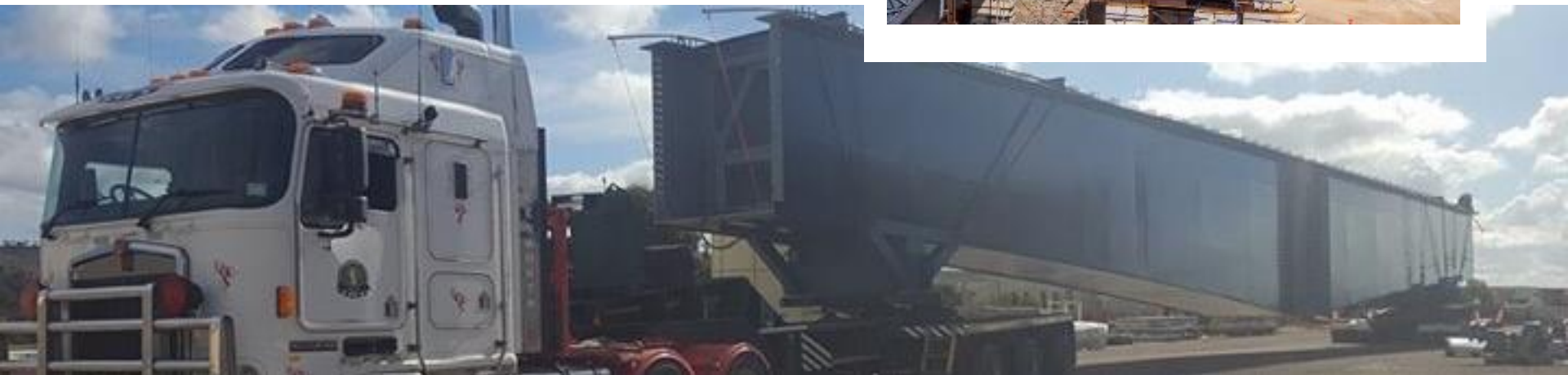

Darlington (cont.)

Darlington Bridge 3, 14 & Temporary Steelwork

During the project Gateway asked us to provide additional scope by way of the temporary steelwork that supported the nearly 12,000t of steel and concrete prior to its installation onto the permanent piers and abutments. Upon inspection, it was found that the initial design had some inefficient features, the clients budget was looking under serious threat. With some quick and innovative thinking between the client, their engineer and Bowhill Engineering staff, the cost to actually complete the temporary steelwork was reduced by some \$400,000, thus saving the clients budget and making the ambitious timeline to supply possible. Credit must be given to the engineer James Deane-Butcher from Robert Bird Group for the cooperative and flexible nature he had to our repeated requests towards tweaking the design to achieve significant efficiencies but still to maintain structural integrity.

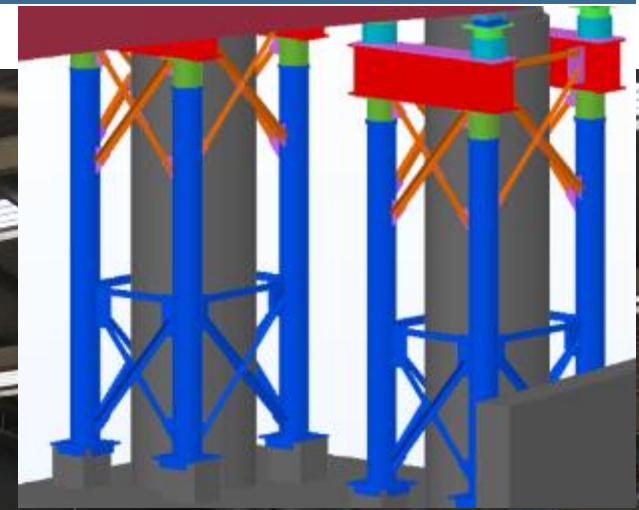

RMS CC3 compliant steelwork for 2 haul road bridges in the Snowy Mountains NSW. FPBW flange to webs, delivered to a remote and difficult to access site location



Collaborative Model Review

Oaklands Railway Station

Client Name: McConnell Dowell

Year Completed: 2018-2019

Oaklands Railway Station Project is a high profile striking architectural statement, it's also a complex structure comprising around 200 tonnes of steelwork. Our Client MCD knew it was important to get the right contractor onto the team as the project's program was of huge importance to them and their client DPTI. The success of the project relied upon an incredibly smooth run and some hard work, we knew from experience that if it was coordinated and planned right, and the total construction team were on the same page, we had every chance of producing the miracle that MCD was after.



Oaklands (cont.)

“ We opened the train station on Monday morning which was amazing to see. Thank you for all your assistance to get to this point. Bowhill have been massive contributors to the project, delivering \$1.5m of steel fabrication.

Bowhill's input and interaction during the latter stages of the design phase provided the Project with some fabrication smarts which was of great benefit with both time and cost.

The detailing by Steve Wurst and Steve Bown was outstanding and they really took on the challenges put before them with the difficult geometry of the canopy structure.

The fabrication and coating performed at Bowhill's workshop was completed to a high quality with minimal fuss and any hiccups were dealt with by Bowhill without the need for Project intervention. This is a great asset to have as a company and is exactly what the Project team is looking for in a subcontractor.

I look forward to working with Bowhill again on the next project. ”

- Adam Downie, McConnell Dowell

We instigated weekly face to face meetings during the critical model development stage, attended by construction modeler, architect, engineering, MCD, DIT, ourselves and any other trade that was relevant at each stage. Boweng believe that this was the key to the project's success as issues were worked through in real time, all parties providing input allowing modeling to progress without being held back due to frustrating RFI's bouncing around in emails. However, the model wasn't just progressed, the collaborative approach saw many smart design features adopted, not from any one person's idea, but from a combination of everyone's knowledge and varied perspectives mixed into developing the final solution. We also brought peace of mind to the technical requirements due to having been CC3 certified to the NSSCS for a year already prior to starting work.



Unique, safe and efficient solution

O'Bahn Tunnel Props & Whalers (Temporary Works)

Client Name: McConnell Dowell

Year Completed: 2016-2017

During this project, there was an opportunity to develop an Innovative prop and prop release system to release the force from the temporary horizontal 300mm diameter CHS props once the permanent works were completed and the props were redundant. McConnell Dowell representative Jan Siebel suggested in a passing comment the possibility of using sand as the support and release system as they had used a similar system previously in a different format (vertical support and release of a large load) but they didn't really know how to achieve the different feat at the time. Taking this idea on as a challenge was instinctual for Bowhill Engineering with physical development initiated almost immediately utilising a sliding collar arrangement never before developed. Prototype and testing revealed that there was potential for this system to work successfully in the horizontal plane on a CHS prop.



O'Bahn (cont)

Engineering calculations and witnessed load testing/measurement completed the process with some slight tweaks and a setting procedure was formulated tested and documented. McConnell Dowell then verified our work through Aztec Analysis and production of the system onto all 50 units was rolled out. This system was seamless and the safety and productivity gains for our client was significant with release of the units being as simple as the removal of a drain bung, once force was released the props sat safely in place until their removal with a crane! The alternative prop release process that was proposed was a clunky method of using a custom hydraulic jack to ease the weight from each prop to enable release, all of this between 5-12m in the air and close to the top of the tunnel's recently installed concrete lid.



Award Winning Delivery Solution

Majors Road – Southern Expressway

Client Name: Lend Lease

Year Completed: 2014

Our clients budget for this work was tight which necessitated innovative thinking for us to be able to deliver the quality outcome, within budget. Transport was the key innovation that resulted in a very successful outcome for our client and for Bowhill Engineering.

32.5m long members are not straight forward to deliver to site in Adelaide's South. Our clients budget for this work was tight which necessitated innovative thinking for us to be able to deliver the quality outcome, within budget.



Major's (cont.)

“The surety that we realised through the delivery solution was outstanding, our installation process benefited greatly because of the flexibility that we had around crane and weather delays allowing for absolute control of our site resources without costly delay implications”

- Kevin Shine, Project Engineer, Lend Lease



32.5m long members are not straight forward to transport to any site, let alone Adelaide's South. To minimise traffic disruption and maximise efficiency, the decision was made to move all 8 bridge girders (total of nearly 80t) to the site in one movement. This saw the design of a purpose built transport and storage cradle to ensure a safe and damage free end result. Cradle had to allow the specific truck trailer combination enough room to reverse under the load, this heavy lift deck had the ability to hydraulically raise the trailer deck under the load which allowed the removal of the bolted legs once the load was secured on the trailer with a reverse of this methodology on site for unloading. Engineering calculations and detailed shop drawings were completed to allow for a safe, smooth and problem free execution of the plan.

The custom designed and built transport/storage cradle minimised damage to the coating system in the whole of project handling, zero double handling and maximum cure times were possible due to the methodology, this ensured a successful end result.

The delivery was coordinated so that the whole load was positioned directly adjacent to the permanent bridge site which allowed our client surety to directly unload and install the beams at their absolute convenience and without the need to double handle the heavy, yet delicate items. It proved to be a safe and efficient methodology of both transport and handling on site due to the reduced number of oversize loads on our public roads. There was an added bonus of not having the normal and often difficult coordination of site staff and expensive lifting equipment mobilisation and re-mobilisation for unloading of the items upon their immediate arrival on site on a weekend. This project won an Innovation Award through Lend Lease's National Operations.

New launch method saves client 2 months

River Murray Ferry Hulls

Client Name: DPTI

Year Completed: 2014-2018

Innovative Methodologies: Soon after award, Bowhill Engineering was able demonstrate proposals and work closely with the DPTI's design team to coordinate many constructability improvements, especially the longitudinal connection of the hull. Using our geographic location to our strength (next to the River Murray) we were able to build the 12m wide, 22m long 70t ferry complete at our manufacture facility (previous builds had been road freighted to Morgan in two halves). The benefits to the client included structural integrity, coating integrity, accuracy, and conveniently allowing DPTI to continue using their Morgan Slipway for some 2 months longer.

Technical Challenges: Large components, transported via river channel to DPTI dockyard.

Using a bold approach to this challenge we factored in an allocation for extensive temporary steelwork.

We designed this temporary steelwork together with our own engineering and drafting team to be able to launch the completed ferry at the river just metres from our manufacture facility. The coordination between permanent and temporary work packages was the key to the successful launch. The extensive modelling and simulation was done early to bring surety to the process.

Successful Outcomes: A slick methodology was the key to the success for this project, the large components being built on our site had to be planned and as a result the amount of DPTI's site activities were drastically reduced, a safer and much more convenient outcome for our client DPTI. 4 ferries were built in total over 4 years and 2 separate contracts.

Coating Details: Highly scrutinised 3 coat system internal and external on large modules..



Precision Pays off

Wayville Train Station 50m long Pedestrian Overpass

Client Name: McConnell Dowell

Year Completed: 2013-2014

Manufacture technique was critical to achieving success on this complex project. The Bowhill Engineering Team were able to be involved right from the start of the design process, allowing us to work closely with the clients design team to coordinate the longitudinal connection points with all disciplines in mind. The important design consideration included structural integrity, aesthetic implications, coating integrity, accuracy, transportability and assembly on site.

With this Complex 3 dimensional shape, irregular bays, and a tight timeline there were many traps, but we used a professional approach to this challenge and factored in an allocation for extensive temporary steelwork into our bid.



Wayville (cont.)

With close coordination we designed this temporary steelwork together with our own engineering and drafting professionals to mistake proof our permanent fabricated items. We treated the temp steel like part of the product and gave it the attention that it needed to achieve the precision. This coordination was the key to the successful manufacture and problem free fit up of the modules on site over the operating rail corridor (closed for only 2 hours to install each half).

Accuracy was the key to the success of this project, the very complex project progressed on schedule with the amount of site activities reduced and made safer for all trades due to the sound methodology that was developed at the start of the project.

The highly scrutinised 3 coat system with architectural finish top coat on 13 of large modules required minimal site repairs due to the bolted connection between the modules.



Tripling a mines capacity

Mindarie Mineral Sands Feed Hopper

Client Name: Murray Zircon

Year Completed: 2014

Murray Zircon had an ongoing throughput issue (bottle neck) in their mineral sands mining process. The in-pit feed hopper was not performing, it was inconsistent (constant hang-ups), and was constructed in a way that made clean up and maintenance highly restrictive and simply unsafe. Wayne Oliver the Maintenance Manager at Murray Zircon invited the Bowhill Engineering team to get involved in concept design for a new hopper, however the new hopper was to suit the existing mechanical equipment that was deemed still to be suitable. What followed was a fluent process whereby the engineering, drafting, client input and constructability were able to be considered carefully by way of the Tekla 3D model that was shared around electronically to the whole group via free viewing/visualisation software Bimsight. The newly designed feeder unit seemed to satisfy all client/operator requirements but also allowed efficiency from a manufacture and methodology perspective. Having a well-articulated design with in-built constructability efficiencies allowed Bowhill Engineering to quote with certainty on a known amount of scope with a competitive fixed price lump sum.



Tripling a mines capacity (cont.)

Survey of in-use existing equipment was necessary to ensure that fit up of re-used mechanical equipment was accurately detailed. The concept was based around the actual site requirements and product characteristics, with a high degree of importance placed on safe maintenance and operations personnel access and product capacity and material flow.

Because of the interactive and collaborative approach taken by Boweng and their design team, the engineer, draftsman and the client, a well worked model was produced and thoroughly scrutinised by all stakeholders with a multitude of different perspectives, without onerous design meetings and travel time etc. Murray Zircon stakeholders were ecstatic with the end result as the new feeder unit outperformed the existing unit by more than 100% going from some 150-200t per hour average to a consistent 500t per hour with the new unit and virtually no cleaning inside the unit. Existing Unit was stripped, new unit was delivered, assembled and commissioned within 48 hrs due to careful attention to detail and good fit up of components both new and existing.

“ We found the Bowhill team so easy to deal with, the process that they coordinated got the best out of everyone and the end result was impressive both in terms of reliable throughput, but also cleaning and maintenance of the unit in service. I would recommend Bowhill, particularly for projects that require innovative solutions ”

- Wayne Oliver Murray Zircon Maintenance Manager



NEXY Pedestrian Bridge over the Gawler River

Client Name: York Civil / Fult on Hogan

Year Completed: 2010

Scope of Project: Supply fabricate and surface treat and transport to site 2 bridge girders @ approx. 33m long each.

Innovative methodologies: By fabricating the 60m long bridge in 1 section (before we then separated it into its two sections), we were 100% confident of the correct fit up on site. This was important due to the size/cost of the lifting and access equipment on site to install the members.

Technical challenges: The fabrication of this job went very smoothly due mainly to the synchronisation of our drafting with the fantastic service we received from Pipe Profiling services in Queensland and the staff at PPS even helped us to develop a sound methodology for fabrication.

Technical challenges (cont.): We seriously didn't

need to touch these pipes, they were cut so accurately. Not bad considering the multiple pipe connections, complex cuts and allowance for the pre-cambering of the main 3 stringers.

Coating details: Painting these large sections was achievable through the use of our blasting and painting facility, 33m long sections completed undercover in a purpose built coating facility. Coating system included a full blast and 3 coats with an automotive grade top coat finish, paint mapping and detailed testing/recording.

Successful outcomes: Very highly scrutinised fabrication, welding and surface treatment procedures all completely satisfying our client and the principle DPTI. Quality plans and ITP were completed with little fuss in a professional and detailed and accurate manner.

